

LOGhouse

LOG CABINS SUPPLIER

PRODUCT CATALOGUE 2024

High Quality Log Cabins & Log Homes



01 201 7675 *DUBLIN*

021 243 9151 *CORK* | 090 661 6221 *ATHLONE*

WWW.LOGHOUSE.IE [f/LOGHOUSE.IE](#) [▶](#) [@](#) [f](#)

The Company

Loghouse was first established in Ireland in 2007. With over 7500 installations to date we are Ireland's leading supplier of log cabins and garden outbuildings. We pride ourselves in being able to offer fully bespoke or customised log cabins to the customer's specifications. Currently the company operates from three locations within Ireland. We have a team of in-house sales associates, designers, architects and project managers with over 50 years of combined experience in the building industry.

At **Loghouse** we design and build a comprehensive range of premium quality log houses and cabins intended specifically for the Irish market and the weather conditions that Ireland provides. We offer the widest choice of log buildings available in Ireland which include four and five bedroom homes, holiday chalets, multi function log cabins, garages, and stables.



Why Us

All our structures have been specifically designed for the Irish climate with damp proof membranes, extra window seals, end trims and sealants to protect against the harsh Irish climate. Our foundations are designed to keep dampness away from the structure ensuring a longer lifespan of the building. These measures allow us to offer a written ten-year guarantee direct from our factory. All our timbers are from slow grown Scandinavian Pine and are FSC (Forest Stewardship Council) certified, certificates available upon request. Our people are well trained in their fields, safety certified and bonded for your reassurance. We practice CPD (Continuous Professional Development) as part of our commitment to stay up to date with the newest ideas, standards and techniques within the industry.



Our Factory

Our state of the art factory was established in 1995. Currently there are over 200 staff manufacturing all components of the cabin from the structural timbers to the doors and windows to the roof cladding. This guarantees a level of quality within the structure eliminating outsourcing from multiple manufacturers. All our timber is treated and milled by the finest German made machinery to the highest of tolerances. Our factory uses all of the timber purchased, where offcuts are used in glue laminate manufacturing and even the sawdust is reconstituted into wood pellets for stoves.

Tailor-made Building Solutions

At **Loghouse**, we offer a "bespoke" or custom design service to tailor all our pre-engineered models to your needs or start from scratch with your own idea with help from our highly qualified team of planners and log cabin experts, we will guide you through the design process. Our staff can provide working drawings, three dimensional renderings and technical specifications to suit your specific design so you can "see it" in real time before it is even built.



Log House buying Checklist

Ask The Question	Loghouse	Competitor
Safety Glass	✓	
Full Company Insurance	✓	
FSC Certification (FSC-C016970)	✓	
Structural Bond for habitable dwellings	✓	
Fully Bonded 10 year Manufacturers Guarantee	✓	
Safe Pass Employees Trained Installation Technicians	✓	
Over 50 years experience in Log Cabins & Construction Industry	✓	
Quality of Timber Scandinavian Pine	✓	
Is the model available for viewing?	✓	
All Doors and Windows – premium living type, glue-laminated frames, 5x point clocking, 24mm argon gas filled double glazing, built-in micro ventilation. Meets or exceeds Irish building standards for domestic building	✓	
Exterior wall covers on end of log junctions	✓	
Rainwater skirting flare around the cabin	✓	
Standard completion list at the end of the build	✓	
Free weathering package for better protection on all cabins	✓	
Dedicated after sales & quality control teams	✓	
More than 6000 cabins assembled Nationwide	✓	
5x showrooms across Dublin, Cork & Athlone	✓	
External insulation & shiplap cladding option for better protection & extended longevity	✓	
Steel flashings and fascias on all roofs as standard	✓	
In-house groundworks & plumbing service to avoid expensive subcontractors & save all the hassle.	✓	
Pressure treated floor bearers as standard on all cabins	✓	

Loghouse Quality Guaranteed

Did you know that Loghouse is the only fully certified, insured and bonded log cabin company in Ireland? We carry the following certifications and bonds:

1 FSC Certification. FSC forest management certification confirms that the forest is being managed in a way that preserves the natural ecosystem and benefits the lives of local people and workers, while ensuring it sustains economical viability. Ask to see this from our competitors.

2 As your building is 100% timber it is very important to ensure that your cabin is made from good quality wood to avoid problems like warping, twisting or excessive settling due to timber that has not been dried sufficiently. Where it is grown and how it is cured is of exceptional importance.

3 If the log house is to be a habitable dwelling a 10-year structural guarantee from Global Warranties.

This means your project would be visited at various stages of construction and signed off as completed as per best build practices and building regulations by qualified surveyors and industry professionals.

4 Public liability insurance, product and installation guarantee. We carry the most insurance of any of our competitors in the industry and our insurance certs are on display in all our showrooms. Also on display are the manufacturer's guarantee and our own guarantee of trained, qualified service professionals. All our installers are safe pass certified before they are allowed to walk on a site.

✗ Ask to see the competitors credentials as it may save you the price of the cabin if they do not have the correct coverage and training.

✗ Beware of companies operating with little to no insurance, have the correct training and bonds and always request these documents before making a decision to buy. Your purchase of a cabin is important to you, so take the time and seek a company that not only stands behind their products, but also backs it up with the paperwork to ensure you do not lose your investment should any damages occur or warranty work is required.

Plumbing & Electrical Works Guidelines

All plumbing, heating, sewage, water mains connection, kitchen and bathroom works are carried out by our in-house team of experts. Please contact us for more details.

PRICE GUIDE:

- Plumbing €1,000 – €2,500
- Heating €1,000 – €5,000
- Sewage & water mains €1,500 – €3,000
- Kitchen €1,000 – €5,000
- Bathroom €1,500 – €5,000
- Electrical per point €65 – €85
- Main electrical connection starting from €15 per linear meter.
- Ground screws from €90/m²

All prices are subject to site survey and clients specification.

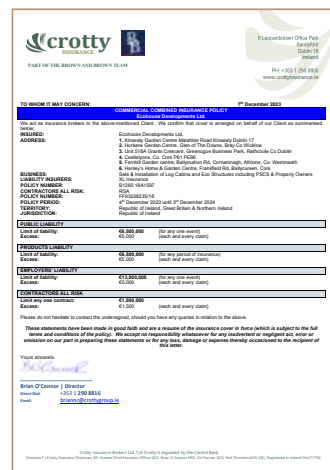

Windows & Doors

Loghouse setting a new standard again!

We are delighted to announce that all our log cabins now include 68mm glue-laminated windows and doors. Designed specifically for the Irish climate – definitely the best windows and doors on the market!

The main materials for glue-laminated timber window is pre-engineered, glued laminated pine. The main advantages of glue-laminated timber windows are considered their high strength, high levels of noise prevention, thermal insulation, long service period,

environmental safety and attractive appearance.

24mm Argon gas filled double glazing improves thermal efficiency by 16-30% and should not lose more than 5% of the total gas over a period of 25 years.

Other advantages of Loghouse.ie windows & doors



✓ Anti Warp
68mm Glulam
frame designed
for damp Irish
climate



✓ Aluminium
thresholds



✓ Twin rubber
seals & extra
strong hinges



✓ 3 position
window
with micro
ventilation



✓ 5 Point locking
system

Most of our competitors window and door standards



✗ Basic doors
45 mm solid
wood – industry
standard



✗ Basic hinges



✗ Single point
locks



✗ Softwood
frame with
basic fittings



✗ Manual tilt
& turn operation



- Cost and time savings
- No digging, no concreting required
- Proven high pressures and pulling-out force
- Instantly loadable with no waiting period
- Sustainable and environmentally-friendly

We have teamed up with Smart Foundations Ireland to provide our clients with a solution for concrete-free foundations at an affordable cost!

Ground screws are installed without digging and damaging your garden or the environment, reducing your carbon footprint. Foundations with ground screws are stable for decades, yet environmentally friendly and removable if necessary. This is the easiest and most cost-effective way to get a timber base done for your garden room or log cabin.

Option 1: A fully insulated timber frame base is constructed from treated 4x2 inch (50x100mm) timber and supported by ground screws. The base is insulated with EPS 70 100mm and finished with 18mm T&G OSB board, creating a strong, insulated slab ready for flooring.



Option 2: Timber-frame base made out of treated 6x2 inch (50x150mm) timber and supported by ground screws, super sturdy and ready to be built immediately after the installation. Eco-friendly option and can be relocated if needed with minimum disturbance to the surroundings.



smartfoundationsireland

smartfoundationsIRL



Mob: 087 657 5592

Email: info@smartfoundations.ie

www.smartfoundations.ie



AJ QUALITY FURNITURE



AJ Quality Furniture is working with us to help out you on any bespoke furniture needs you may have.

That will include kitchens, wardrobes & custom made cabinets to work around the cabin space like never before and provide you with many options to use the space you have in the most practical way possible.

Kitchens is one of the biggest questions we get asked when buying a residential cabin.

From now on instead of going and looking for options or best price, we offer you a consultation option with us and our kitchen partner to discuss your options and most suitable designs.



Its a hassle free option for all our customers and us to give you a full stop shop with our service, that is carried out by a professional furniture company that knows our cabins as well as we do.



AJ Quality Furniture has designed kitchens for most of our residential cabins with a lot practical solutions for relatively limited spaces.



We have standard designs that we think work best from experience and selling a lot of these kitchens for Loghouse clients.

There is an exclusive range of doors & finishes that can be chosen that have to be discussed with the **AJ Quality Furniture** sales team.

Bespoke options are always available & any custom changes are welcome with subject to price change.



Please don't hesitate to enquire and find out what options & pricing is available.



Tel: +353 87 2790488 | Email: ajqualityfurniture@gmail.com

Athy 3m x 2m



FREE
GERMAN MADE
SECURITY PIC
WINDOW & DOOR UPGRADE
(WHILE STOCK LAST)

Price
€4,140

Delivered in flatpack

Price includes:

FREE steel roofing tiles
FREE damp proof membrane
FREE 50mm floor insulation
FREE weathering package

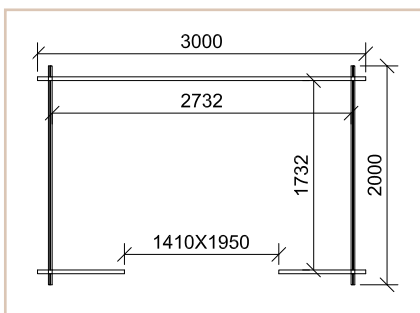
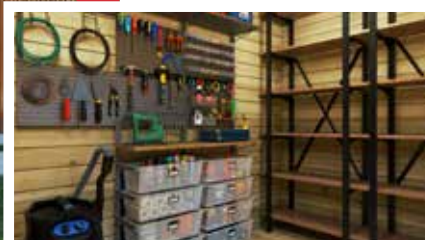

* Includes foundation cover up to 30cm + single step (width of the door).

** Add on to External wall insulation + Shiplap cladding option.

Cabin Details:

Wall thickness	45mm
Size	3m x 2m (9.8ft x 6.6ft)
Doors	Premium living type door
Roof	Steel roof tiles
Ridge height	2160mm
Wall height	1960mm
Floor bearers	45mm x 50mm

Available Upgrades:

Cabin assembly	€550
Timber frame & block pad foundation*	€610
100mm roof insulation	€200
Wall insulation & T&G cladding	€900
External wall insulation & Shiplap cladding	€1,080
Laminated flooring	€235
External painting (excl. paint)	€490
External + Internal (excl. paint)	€700
Gutter & downpipe	€120
Thermowood cladding**	€730

Arklow 3.4m x 2.5m



FREE
GERMAN MADE
SECURITY PIC
WINDOW & DOOR UPGRADE
(WHILE STOCK LAST)

Price
€5,440

Delivered in flatpack

Price includes:

FREE steel roofing tiles
FREE damp proof membrane
FREE 50mm floor insulation
FREE weathering package

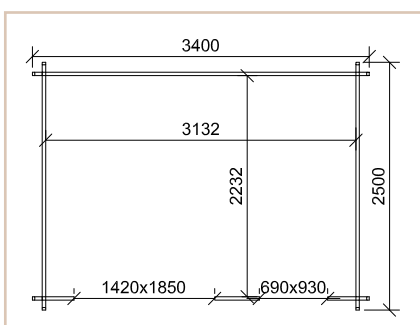
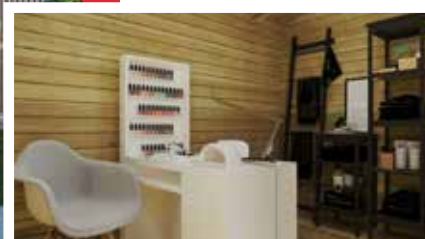

* Includes foundation cover up to 30cm + single step (width of the door).

** Add on to External wall insulation + Shiplap cladding option.

Cabin Details

Wall thickness	45mm
Size	3.4m x 2.5m (11.2ft x 8.2ft)
Doors	Premium living type door
Windows	Premium living type window
Roof	Steel roof tiles
Ridge height	2450mm
Wall height	2050mm
Floor bearers	45mm x 50mm

Available Upgrades

Cabin assembly	€740
Timber frame & block foundation*	€830
100mm roof insulation	€270
Wall insulation & T&G cladding	€1,170
External wall insulation & Shiplap cladding	€1,390
Laminated flooring	€330
External painting (excl. paint)	€630
External + Internal (excl. paint)	€950
Gutters & downpipes	€210
Thermowood cladding**	€950

Laragh 3m x 3m, 3m x 4m



Price includes:

- FREE** steel roofing tiles
- FREE** damp proof membrane
- FREE** 50mm floor insulation
- FREE** weathering package
- Delivered in flatpack



Cabin Details:	
Wall thickness	45mm
Overall Size	3m x 3m (9.8ft x 9.8ft) or 3m x 4m (9.8ft x 13ft)
Doors	Premium living type door
Windows	Premium living type windows
Roof	Steel roof tiles
Ridge height	2450mm
Wall height	2050mm
Floor bearers	45mm x 50mm

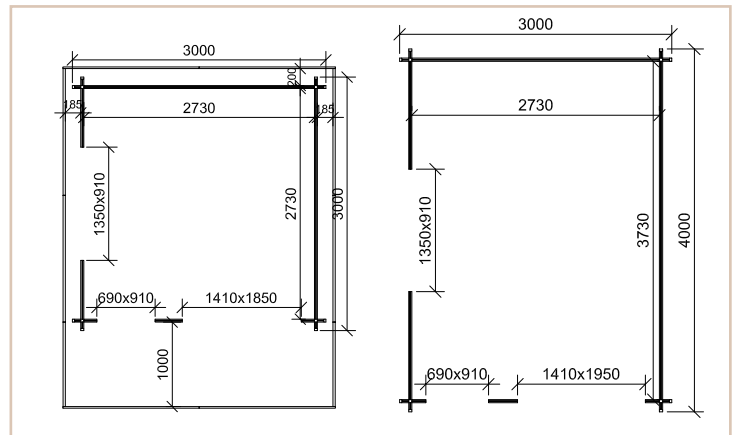

Price	€6,260	€6,980
Available upgrades	3m x 3m	3m x 4m
Cabin assembly	€780	€1,000
Timber frame & block foundation*	€870	€940
100m roof insulation	€290	€370
Wall insulation & T&G cladding	€1,170	€1,360
External insulation & Shiplap cladding	€1,390	€1,630
Laminated flooring	€350	€470
External painting (excl. paint)	€580	€680
External + Internal painting (excl. paint)	€1,100	€1,150
Gutters & downpipes	€240	€300
Thermowood cladding**	€970	€1,120

* Includes foundation cover up to 30cm + single step (width of the door).

** Add on to External wall insulation + Shiplap cladding option.

Greystones 4m x 3m & 4m x 4m



Price includes:

- FREE** steel roofing tiles
 - FREE** damp proof membrane
 - FREE** 50mm floor insulation
 - FREE** weathering package
- Delivered in flatpack



Cabin Details:	
Wall thickness	45mm
Overall Size	4m x 3m (13ft x 9.8ft) or 4m x 4m (13ft x 13ft)
Doors	Premium living type door
Windows	Premium living type windows
Roof	Steel roof tiles
Ridge height	2450mm
Wall height	2110mm
Floor bearers	45mm x 50mm

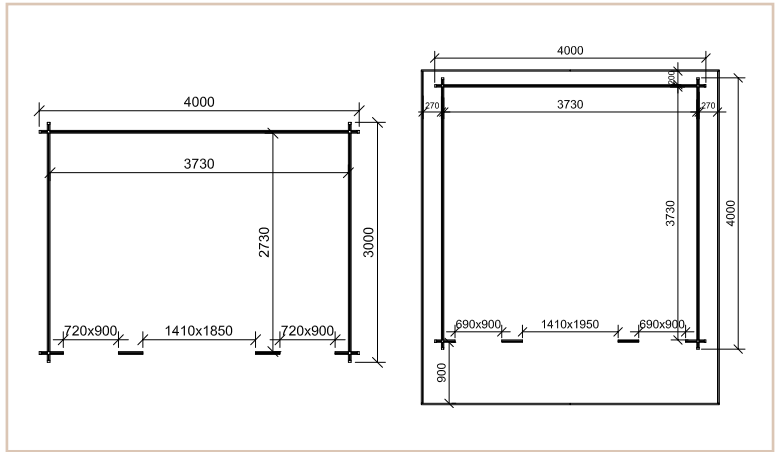

Price	€6,840	€7,690
Available upgrades	4m x 3m	4m x 4m
Cabin assembly	€1,000	€1,300
Timber frame & block foundation*	€940	€1,140
100m roof insulation	€370	€470
Wall insulation & T&G cladding	€1,380	€1,580
External insulation & Shiplap cladding	€1,660	€1,890
Laminated flooring	€470	€625
External painting (excl. paint)	€680	€740
External + Internal (excl. paint)	€1,150	€1,280
Gutters & downpipes	€240	€300
Thermowood cladding**	€1,400	€1,580

* Includes foundation cover up to 30cm + single step (width of the door).

** Add on to External wall insulation + Shiplap cladding option.



Price
€7,250

Delivered in flatpack

Price includes:

- FREE** steel roofing tiles
- FREE** damp proof membrane
- FREE** 50mm floor insulation
- FREE** double glazed windows & doors
- FREE** weathering package



Cork 4m x 3m

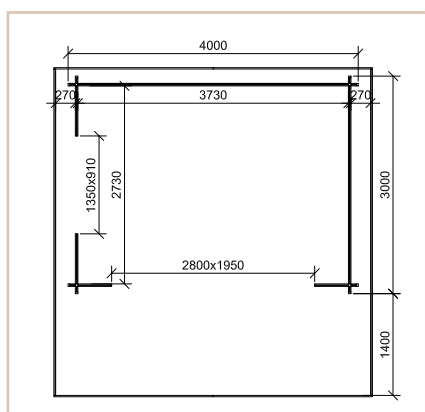

Cabin Details

Wall thickness	45mm
Size	4m x 3m (13ft x 9.8ft)
Doors	Premium living type door
Windows	Premium living type windows
Roof	Steel roof tiles
Ridge height	2450mm
Wall height	2110mm
Floor bearers	45mm x 50mm

* Includes foundation cover up to 30cm + single step (width of the door)

** Add on to External wall insulation + Shiplap cladding option.

Available Upgrades

Cabin assembly	€1,000
Timber frame & block foundation*	€940
100mm roof insulation	€370
Wall insulation & T&G cladding	€1,350
External insulation & Shiplap cladding	€1,620
Laminated flooring	€470
External painting (excl. paint)	€730
External + Internal (excl. paint)	€1,200
Gutters & downpipes	€270
Veranda	€600
Thermowood cladding**	€1,120



Price
€11,650

Delivered in flatpack

Price includes:

- FREE** steel roofing tiles
- FREE** damp proof membrane
- FREE** 50mm floor insulation
- FREE** double glazed windows & doors
- FREE** weathering package

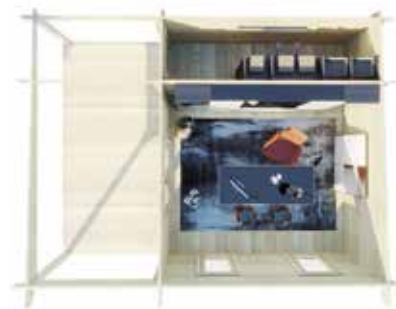

Rathcoole 6m x 4.5m

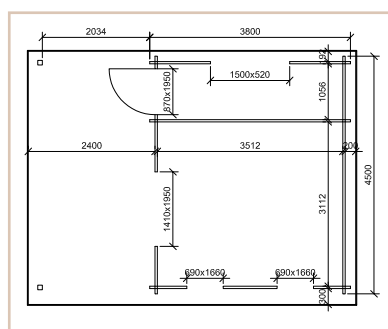

Cabin Details

Walls	45mm
Size	6m x 4.5m (19.7ft x 14.7ft)
Doors	Premium living type door
Windows	Premium living type windows
Roof	Steel roof tiles
Ridge height	2600mm
Wall height	2210mm
Floor bearers	45mm x 50mm

* Includes foundation cover up to 30cm + single step (width of the door).

** Add on to External wall insulation + Shiplap cladding option.

Available Upgrades

Cabin assembly	€2,080
Timber frame & block foundation*	€1,750
100mm roof insulation	€740
Wall insulation & T&G cladding	€1,750
External insulation & Shiplap cladding	€2,050
Laminated flooring	€670
External painting (excl. paint)	€800
External + Internal (excl. paint)	€1,500
Gutters & downpipes	€180
Thermowood cladding**	€1,380

Ashford 4m x 3m, 4m x 4m, 5m x 3m



FREE
GERMAN MADE
SCHUCHO PVC
WINDOW & DOOR UPGRADE
(WHILE STOCK LAST)

Price includes:

- FREE** steel roofing tiles
 - FREE** damp proof membrane
 - FREE** 50mm floor insulation
 - FREE** double glazed windows & doors
 - FREE** weathering package
- Delivered in flatpack



Cabin Details:	
Wall thickness	45mm
Size	4m x 3m (13ft x 9.8ft), 4m x 4m (13ft x 13ft) or 5m x 3m (16ft x 9.8ft)
Doors	Premium living type door
Windows	Premium living type windows
Roof	Steel roof tiles
Ridge height	2415mm
Wall height	2155mm
Floor bearers	45mm x 50mm

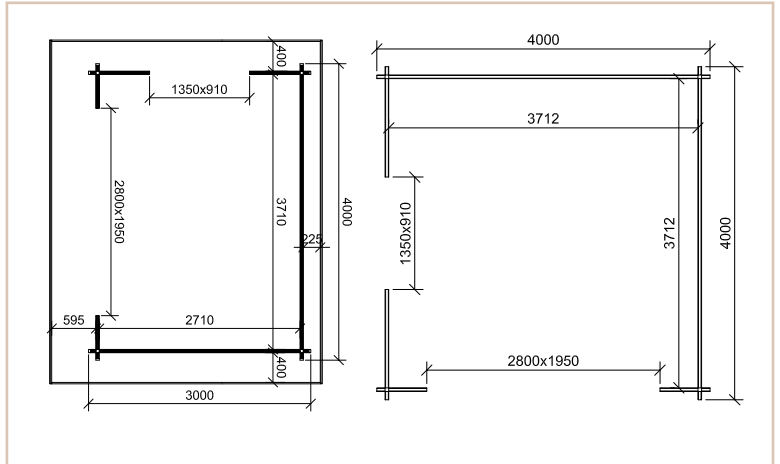

Price	€7,020	€7,750	€7,720
Available upgrades	4m x 3m	4m x 4m	5m x 3m
Cabin assembly	€1,000	€1,300	€1,230
Timber frame & block foundation*	€940	€1,140	€1,080
100m roof insulation	€370	€470	€450
Wall insulation & T&G cladding	€1,290	€1,480	€1,540
External insulation & Shiplap cladding	€1,550	€1,770	€1,890
Laminated flooring		€625	€585
External painting (excl. paint)	€650	€740	€730
External + Internal (excl. paint)	€1,120	€1,290	€1,270
Gutter & downpipe	€120	€120	€150
Thermowood cladding**	€1,090	€1,230	€1240

* Includes foundation cover up to 30cm + single step (width of the door).
** Add on to External wall insulation + Shiplap cladding option.

Newcastle 4m x 3m, 4m x 4m, 5m x 3m



FREE
GERMAN MADE
'SCHUCO' PVC
WINDOW & DOOR UPGRADE
(WHILE STOCK LAST)

Price includes:

- FREE** steel roofing tiles
 - FREE** damp proof membrane
 - FREE** 50mm floor insulation
 - FREE** double glazed windows & doors
 - FREE** weathering package
- Delivered in flatpack



Cabin Details:	
Wall thickness	45mm
Size	4m x 3m (13ft x 9.8ft), 4m x 4m (13ft x 13ft) or 5m x 3m (16ft x 9.8ft)
Doors	Premium living type door
Windows	Premium living type windows
Roof	Steel roof tiles
Ridge height	2500mm
Wall height	2100mm
Floor bearers	45mm x 50mm

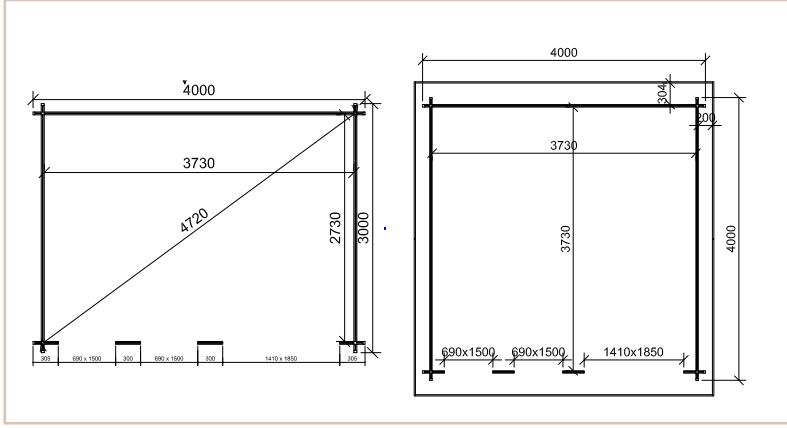

Price	€6,980	€7,750	€8,030	€8,790
Available upgrades	4m x 3m	5m x 3m	4m x 4m	6m x 3m
Cabin assembly	€1,000	€1,230	€1,300	€1,350
Timber frame & block foundation*	€940	€1,080	€1,140	€1,190
100mm Roof insulation	€370	€450	€470	€530
Wall insulation & T&G cladding	€1,380	€1,580	€1,580	€1,780
External insulation & Shiplap cladding	€1,660	€1,890	€1,890	€2,140
Laminated flooring	€470	€585	€625	€710
External painting (excl. paint)	€680	€740	€740	€830
External + Internal (excl. paint)	€1,150	€1,280	€1,280	€1,320
Gutters & downpipes	€240	€300	€240	€360
Thermowood cladding**	€1,130	€1,290	€1,340	€1,440

* Includes foundation cover up to 30cm + single step (width of the door).
** Add on to External wall insulation + Shiplap cladding option.



Price
€8,850

Delivered in flatpack

Price includes:

- FREE** steel roofing tiles
- FREE** damp proof membrane
- FREE** 50mm floor insulation
- FREE** double glazed windows & doors
- FREE** weathering package



Leitrim

4.8m x 3.5m

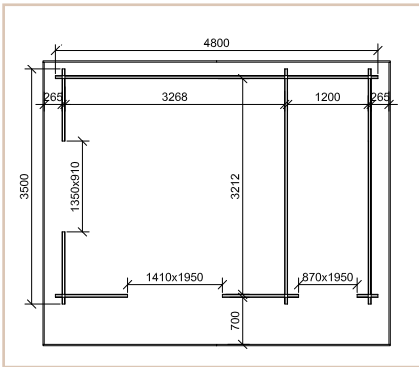

Cabin Details

Wall thickness	45mm
Size	4.8m x 3.5m (15.7ft x 11.5ft)
Doors	Premium living type doors
Windows	Premium living type windows
Roof	Steel roof tiles
Ridge height	2535mm
Wall height	2145mm
Floor bearers	45mm x 50mm

* Includes foundation cover up to 30cm + single step (width of the door).

** Add on to External wall insulation + Shiplap cladding option.

Available Upgrades

Cabin assembly	€1,350
Timber frame & block foundation*	€1,310
100mm roof insulation	€520
Wall insulation & T&G cladding	€1,640
External insulation & Shiplap Cladding	€1,970
Laminated flooring	€655
External painting (excl. paint)	€780
External + Internal (excl. paint)	€1,350
Gutters & downpipes	€250
Thermowood cladding**	€1,390



Price
€8,580

Delivered in flatpack

Price includes:

- FREE** steel roofing tiles
- FREE** damp proof membrane
- FREE** 50mm floor insulation
- FREE** double glazed windows & doors
- FREE** weathering package



Dundrum

5m x 3m

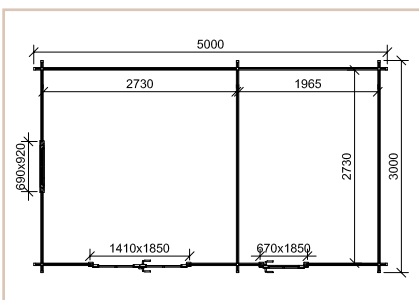

Cabin Details

Walls	45mm
Size	5m x 3m (16.4ft x 9.8ft)
Doors	Premium living type doors
Windows	Premium living type windows
Roof	Steel roof tiles
Ridge height	2650mm
Wall height	1810mm / 2310mm
Floor bearers	45mm x 50mm

* Includes foundation cover up to 30cm + single step (width of the door).

**Add on to External wall insulation + Shiplap cladding option.

Available Upgrades

Cabin assembly	€1,230
Timber frame & block foundation*	€1,080
100mm roof insulation	€450
Wall insulation & T&G cladding	€1,630
External insulation & Shiplap cladding	€1,950
Laminated flooring	€585
External painting (excl. paint)	€820
External + Internal (excl. paint)	€1,550
Gutters & downpipes	€210
Thermowood cladding**	€1,400

Dublin



Price includes:

- FREE** steel roofing tiles
- FREE** damp proof membrane
- FREE** 50mm floor insulation
- FREE** double glazed windows & doors
- FREE** weathering package

Delivered in flatpack



Cabin Details:

Wall thickness	45mm
Size	4m x 4m, 4m x 5m, 5m x 4m, 6m x 4m, 5m x 5m
Doors	Premium living type door
Windows	Premium living type windows
Roof	Steel roof tiles
Ridge height	2535mm
Wall height	2145mm
Floor bearers	45mm x 50mm

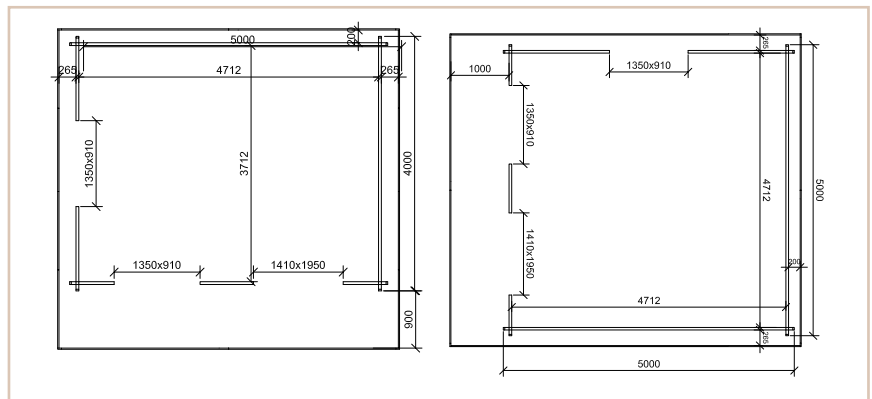

Price	€8,340	€9,140	€9,140	€10,190	€10,120
Available upgrades	4m x 4m	4m x 5m	5m x 4m	6m x 4m	5m x 5m
Cabin assembly	€1,300	€1,600	€1,600	€1,900	€1,980
Timber frame & block foundation*	€1,140	€1,400	€1,320	€1,570	€1,630
100m roof insulation	€470	€580	€580	€680	€700
Wall insulation & T&G cladding	€1,580	€1,780	€1,780	€2,030	€1,980
External insulation & Shiplap cladding	€1,890	€2,140	€2,140	€2,440	€2,370
Laminated flooring	€625	€780	€780	€925	€975
External painting (excl. paint)	€850	€910	€910	€940	€910
External + Internal (excl. paint)	€1,290	€1,450	€1,450	€1,550	€1,650
Gutters & downpipes	€300	€360	€300	€300	€360
Veranda	€540	€660	€660	€800	€660
Thermowood cladding**	€1,320	€1,470	€1,500	€1,730	€1,650

* Includes foundation cover up to 30cm + single step (width of the door). ** Add on to External wall insulation + Shiplap cladding option.

Kilkenny



Price includes:

- FREE** steel roofing tiles
- FREE** damp proof membrane
- FREE** 50mm floor insulation
- FREE** double glazed windows & doors
- FREE** weathering package

Delivered in flatpack



Cabin Details:

Wall thickness	45mm
Size	4m x 3m, 5m x 3m, 4m x 4m, 6m x 3m, 5m x 4m, 6m x 4m, 5m x 5m
Doors	Premium living type door
Windows	Premium living type windows
Roof	Steel roof tiles
Ridge height	2500mm
Wall height	2100mm
Floor bearers	45mm x 50mm

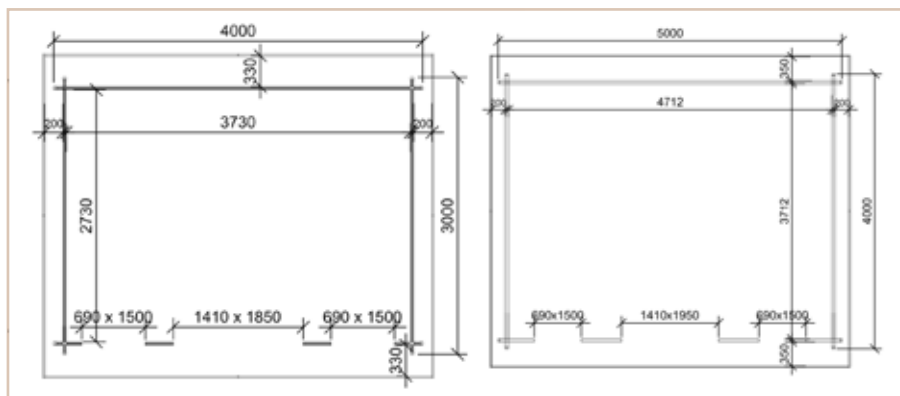

Price	€6,980	€7,750	€8,030	€8,790	€8,940	€9,850	€9,870
Available upgrades	4m x 3m	5m x 3m	4m x 4m	6m x 3m	5m x 4m	6m x 4m	5m x 5m
Cabin assembly	€1,000	€1,230	€1,300	€1,350	€1,600	€1,900	€1,980
Timber frame & block foundation*	€940	€1,080	€1,140	€1,190	€1,320	€1,570	€1,630
100m roof insulation	€370	€450	€470	€530	€580	€680	€700
Wall insulation & T&G cladding	€1,380	€1,580	€1,580	€1,780	€1,780	€1,980	€2,050
External insulation & Shiplap cladding	€1,660	€1,890	€1,890	€2,140	€2,140	€2,370	€2,450
Laminated flooring	€470	€585	€625	€710	€780	€935	€975
External painting (excl. paint)	€680	€740	€740	€830	€910	€940	€910
External + Internal (excl. paint)	€1,150	€1,280	€1,280	€1,320	€1,450	€1,550	€1,650
Gutters & downpipes	€240	€300	€240	€360	€300	€360	€300
Thermowood cladding**	€1,130	€1,290	€1,340	€1,440	€1,500	€1,650	€1,690

*Roof feature not available with steel roof. * Includes foundation cover up to 30cm + single step (width of the door).

** Add on to External wall insulation + Shiplap cladding option.

Kilkenny 2 rooms



FREE
GERMAN MADE
"SCHUCO" PVC
WINDOW & DOOR UPGRADE
(WHILE STOCK LAST)

Price includes:
FREE steel roofing tiles
FREE damp proof membrane
FREE 50mm floor insulation
FREE double glazed windows & doors
FREE weathering package
 Delivered in flatpack



Cabin Details:

Wall thickness	45mm
Size	5m x 3m 5m x 4m 5m x 5m 6m x 4m
Doors	Premium living type door
Windows	Premium living type windows
Roof	Steel roof tiles
Ridge height	2500mm
Wall height	2100mm
Floor bearers	45mm x 50mm

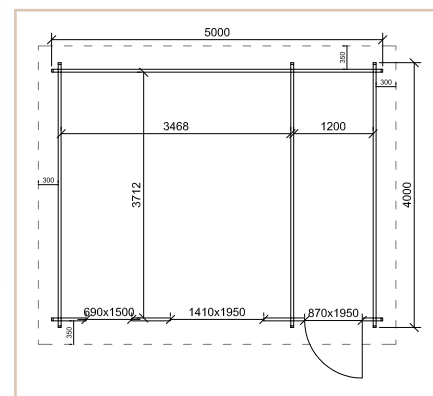

Price	€8,400	€9,700	€9,860	€10,760	€10,910
Available upgrades	5m x 3m	5m x 4m	6m x 3m	6m x 4m	5m x 5m
Cabin assembly	€1,230	€1,600	€1,900	€1,900	€1,980
Timber frame & block foundation**	€1,080	€1,320	€1,570	€1,570	€1,630
100m roof insulation	€450	€580	€680	€680	€700
Wall insulation & T&G cladding	€1,580	€1,780	€1,780	€1,980	€2,050
External insulation & Shiplap cladding	€1,890	€2,140	€2,140	€2,370	€2,450
Laminated flooring	€585	€780	€710	€935	€975
External painting (excl. paint)	€760	€925	€830	€940	€925
External + Internal (excl. paint)	€1,380	€1,500	€1,500	€1,650	€1,500
Gutters & downpipes	€300	€300	€360	€360	€300
Thermowood cladding**	€1,290	€1,500	€1,440	€1,650	€1,690

*Roof feature not available with steel roof. * Includes foundation cover up to 30cm + single step (width of the door).

** Add on to External wall insulation + Shiplap cladding option.

Wicklou



Price includes:

- FREE** steel roofing tiles
- FREE** damp proof membrane
- FREE** 50mm floor insulation
- FREE** double glazed windows & doors
- FREE** weathering package

Delivered in flatpack



Cabin Details:

Wall thickness	45mm
Size	6m x 4m, 5m x 4m, 5m x 5m, 5m x 3m
Doors	Premium living type door
Windows	Premium living type windows
Roof	Steel roof tiles
Ridge height	2600mm
Wall height	2080mm
Floor bearers	45mm x 50mm

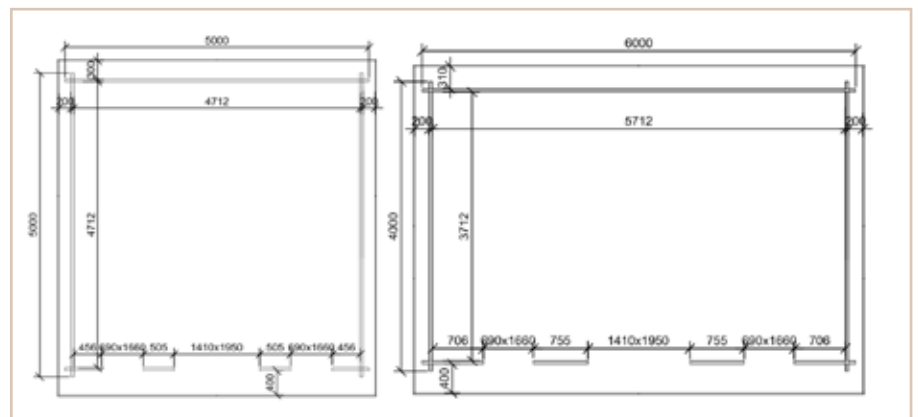

Price	€7,390	€8,710	€8,630	€9,660	€9,800
Available upgrades	5m x 3m	5m x 4m	6m x 3m	6m x 4m	5m x 5m
Cabin assembly	€1,230	€1,600	€1,420	€1,900	€1,900
Timber frame & block foundation*	€1,080	€1,320	€1,140	€1,570	€1,630
100m roof insulation	€450	€580	€530	€680	€700
Wall insulation & T&G cladding	€1,580	€1,780	€2,030	€1,980	€2,030
External insulation & Shiplap cladding	€1,890	€2,140	€2,190	€2,370	€2,440
Laminated flooring	€585	€780	€710	€935	€975
External painting (excl. paint)	€740	€910	€830	€920	€950
External + Internal (excl. paint)	€1,280	€1,450	€1,320	€1,550	€1,650
Gutter & downpipe	€150	€150	€180	€180	€150
Thermowood cladding**	€1,330	€1,500	€1,490	€1,660	€1,740

* Includes foundation cover up to 30cm + single step (width of the door) ** Add on to External wall insulation + Shiplap cladding option.

Wicklow 2 rooms



FREE
GERMAN MADE
"SCHUCO" PVC
WINDOW & DOOR UPGRADE
(WHILE STOCK LAST)

Price includes:
FREE steel roofing tiles
FREE damp proof membrane
FREE 50mm floor insulation
FREE double glazed windows & doors
FREE weathering package
 Delivered in flatpack



Cabin Details:

Wall thickness	45mm
Size	5m x 3m 5m x 4m 5m x 5m 6m x 4m
Doors	Premium living type door
Windows	Premium living type windows
Roof	Steel roof tiles
Ridge height	2600mm
Wall height	2080mm
Floor bearers	45mm x 50mm

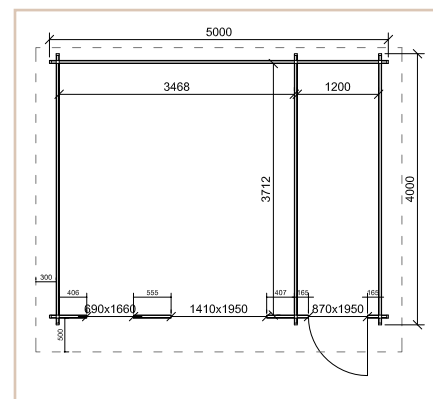

Price	€8,440	€9,740	€9,880	€10,550	€10,990
Available upgrades	5m x 3m	5m x 4m	6m x 3m	6m x 4m	5m x 5m
Cabin assembly	€1,230	€1,600	€1,420	€1,900	€1,980
Timber frame & block foundation*	€1,080	€1,320	€1,140	€1,570	€1,630
100m roof insulation	€450	€580	€530	€680	€700
Wall insulation & T&G cladding	€1,540	€1,780	€2,030	€1,980	€2,030
External insulation & Shiplap cladding	€1,890	€2,140	€2,190	€2,370	€2,440
Laminated flooring	€585	€780	€710	€935	€975
External painting (excl. paint)	€760	€925	€830	€940	€925
External + Internal (excl. paint)	€1,380	€1,500	€1,500	€1,600	€1,500
Gutters & downpipes	€150	€150	€180	€180	€150
Thermowood cladding**	€1,330	€1,500	€1,490	€1,660	€1,740

*Roof feature not available with steel roof. ** Includes foundation cover up to 30cm + single step (width of the door) ** Add on to External wall insulation + Shiplap cladding option.

Wexford



Price includes:
FREE steel roofing tiles
FREE damp proof membrane
FREE 50mm floor insulation
FREE double glazed windows & doors
FREE weathering package
 Delivered in flatpack



Cabin Details:

Wall thickness	45mm
Size	6m x 3m, 6m x 4m,
Doors	Premium living type door
Windows	Premium living type windows
Roof	Steel roof tiles
Ridge height	2600mm
Wall height	2340mm
Floor bearers	45mm x 50mm

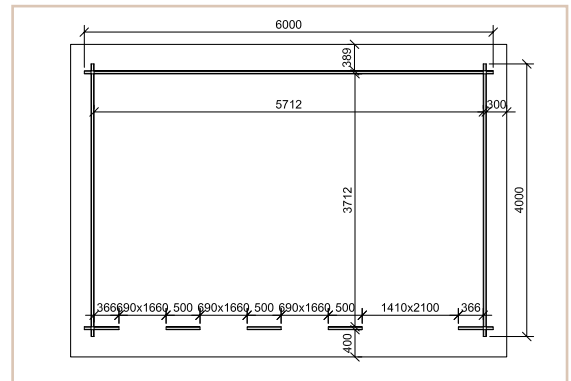

Price	€8,830	€9,960
Available upgrades	6m x 3m	6m x 4m
Cabin assembly	€1,350	€1,900
Timber frame & block foundation*	€1,140	€1,570
100m roof insulation	€530	€680
Wall insulation & T&G cladding	€1,830	€1,980
External insulation & Shiplap cladding	€2,190	€2,370
Laminated flooring	€720	€1,040
External painting (excl. paint)	€830	€920
External + Internal (excl. paint)	€1,320	€1,550
Gutter & downpipe	€180	€180
Thermowood cladding**	€1,490	€1,660



* Includes foundation cover up to 30cm + single step (width of the door) ** Add on to External wall insulation + Shiplap cladding option.

Louth Contemporary Log Cabin

4m x 3m



FREE
GERMAN MADE
SCHUCO PVC
WINDOW & DOOR UPGRADE
(WHILE STOCK LAST)



Price
€12,190

Delivered & assembled

Price includes:

- FREE** damp proof membrane
- FREE** roof & floor insulation (value of €600)
- FREE** weathering package

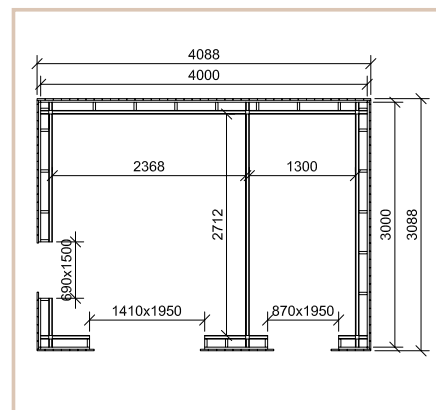

Cabin Details:

Wall thickness	200mm
Size	4m x 3m (13ft x 9.8ft)
Doors	Premium living type door
Windows	Premium living type windows
Roof	Steel roof
Ridge height	2470mm
Wall height	2210mm
Floor bearers	50mm x 45mm

Available Upgrades:

Cabin assembly	Included
Timber frame & block foundation	€1,000
Living type windows & doors	Included
Wall insulation & T&G cladding	Included
Laminated flooring	€470
External painting (excl. paint)	€520
External + Internal (excl. paint)	€1,000
Upgrade to steel roof tiles	Included
Gutter & downpipe	€120
Thermowood cladding**	€1,250

* Includes foundation cover up to 30cm + single step (width of the door)
** Add on to External wall insulation + Shiplap cladding option.

All visuals shown are for illustrations purposes. Actual cabin cabin details may vary.

Clontarf Contemporary Log Cabin

5m x 4m



Price

€14,490

Delivered & assembled

Price includes:

FREE damp proof membrane

FREE roof & floor insulation
(value of €1,000)

FREE weathering package

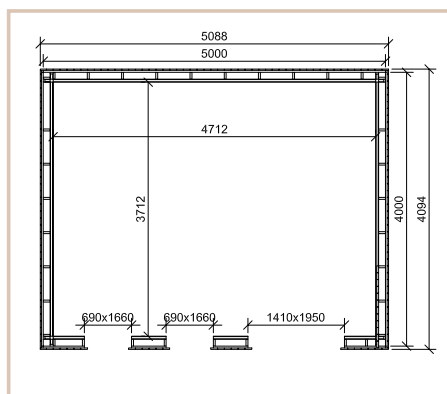

Cabin Details:

Wall thickness	200mm
Size	5m x 4m (16.4ft x 13ft)
Doors	Premium living type door
Windows	Premium living type windows
Roof	Steel roof
Ridge height	2470mm
Wall height	2210mm
Floor bearers	50mm x 45mm

Available Upgrades:

Cabin assembly	Included
Timber frame & block foundation*	€1,420
Living type windows & doors	Included
Wall insulation & T&G cladding	Included
Laminated flooring	€780
External painting (excl. paint)	€820
External + Internal (excl. paint)	€1,550
Upgrade to steel roof tiles	Included
Gutter & downpipe	€150
Thermowood cladding**	€1,600

* Includes foundation cover up to 30cm + single step (width of the door)

** Add on to External wall insulation + Shiplap cladding option.

WWW.LOGHOUSE.IE [f/LOGHOUSE.IE](https://www.facebook.com/LOGHOUSE.IE)

All visuals shown are for illustrations purposes. Actual cabin details may vary.

Ashford Contemporary Log Cabin

4m x 3m, 4m x 4m



FREE
GERMAN MADE
SCHUCO PVC
WINDOW & DOOR UPGRADE
(WHILE STOCK LAST)

Price includes:

- FREE** damp proof membrane
- FREE** roof & floor insulation (value of €600)
- FREE** weathering package



Cabin Details:	
Wall thickness	200mm
Size	4m x 3m (13ft x 9.8ft), 4m x 4m (13ft x 13ft)
Doors	Premium living type door
Windows	Premium living type windows
Roof	Steel roof
Ridge height	2470mm
Wall height	2210mm
Floor bearers	50mm x 45mm

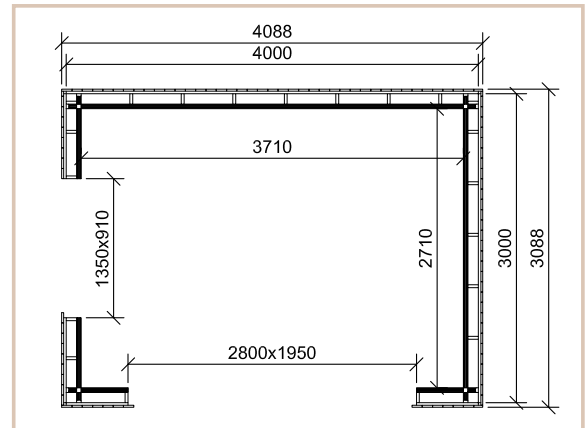

* Includes foundation cover up to 30cm + single step (width of the door)
 ** Add on to External wall insulation + Shiplap cladding option.

Price	€10,830	€12,040
Available upgrades	4m x 3m	4m x 4m
Cabin assembly	Included	Included
Timber frame & block foundation*	€940	€1,140
Living type windows & doors	Included	Included
Wall insulation & T&G cladding	Included	Included
Upgrade to steel roof tiles	Included	Included
Laminate flooring	€470	€625
External painting (excl. paint)	€520	€640
External + Internal (excl. paint)	€1,000	€1,200
Gutter & downpipe	€120	€120
Thermowood cladding**	€1,250	€1,430

BBQ House 6.5m x 3.25m



FREE
GERMAN MADE
'SCHUCHO' PVC
WINDOW & DOOR UPGRADE
(WHILE STOCK LAST)



Price **€12,410**

Delivered in flatpack



Price includes:

- FREE** steel roofing tiles (value of €1060)
- FREE** damp proof membrane
- FREE** 50mm floor insulation (value of €780)
- FREE** weathering package
- FREE** external wall insulation & shiplap cladding

Cabin Details:

Walls	45mm
Size	6.5m x 3.25m (21.3ft x 10.6ft)
Doors	Frameless sliding glass panels
Windows	Frameless sliding glass panels
Roof	Steel roof tiles
Ridge height	2600mm
Wall height	2210mm
Floor bearers	50mm x 100mm

* Includes foundation cover up to 30cm + single step (width of the door).

** Add on to External wall insulation + Shiplap cladding option.

Available Upgrades:

Cabin assembly	€1,590
Timber frame & block foundation*	€1,210
100mm roof insulation	€610
Upgrade to 58mm wall thickness	€900
Wall insulation & T&G cladding	N/A
External painting (excl. paint)	N/A
External + Internal painting (excl. paint)	N/A
Gutters & downpipes	€200
Thermowood cladding**	N/A



FREE
GERMAN MADE
SCHUCO PVC
WINDOW & DOOR UPGRADE
(WHILE STOCK LAST)

Budget One Bed B

6m x 5.2m

Price
€15,110

Delivered in flatpack

Price includes:

FREE steel roofing tiles
(value of €1060)

FREE damp proof
membrane

FREE 100mm floor
insulation (value of €780)

FREE weathering
package

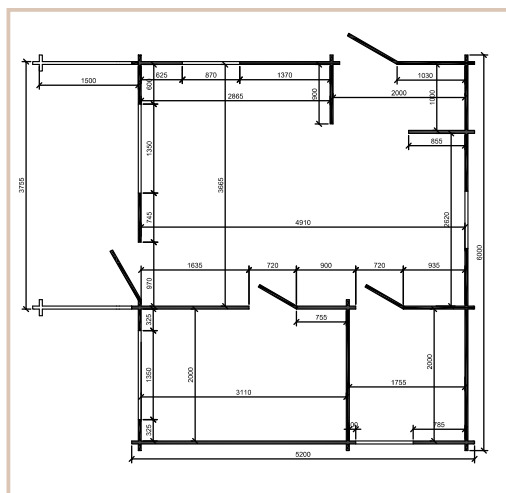

Cabin Details:

Walls	45mm
Size	6m x 5.2m (19.7ft x 17ft)
Doors	Premium living type doors
Windows	Premium living type windows
Roof	Steel roof tiles
Ridge height	2930mm
Wall height	2210mm
Floor bearers	50mm x 100mm

* Includes foundation cover up to 30cm + single step (width of the door).

** Add on to External wall insulation + Shiplap cladding option.

Available Upgrades:

Cabin assembly	€2,260
Timber frame & block foundation*	€1,980
100mm roof insulation	€840
Wall insulation & T&G cladding	€2,090
External wall insulation & Shiplap cladding	€2,590
Laminated flooring	€1,215
External painting (excl. paint)	€1,170
External + Internal painting (excl. paint)	€2,390
Gutters & downpipes	€360
Thermowood cladding**	€1,930

Budget One Bed C 4m x 7m



Price includes:

FREE steel roofing tiles (value of €1060)

FREE damp proof membrane

FREE 100mm floor insulation (value of €780)

FREE weathering package

Price **€13,290**

Delivered in flatpack

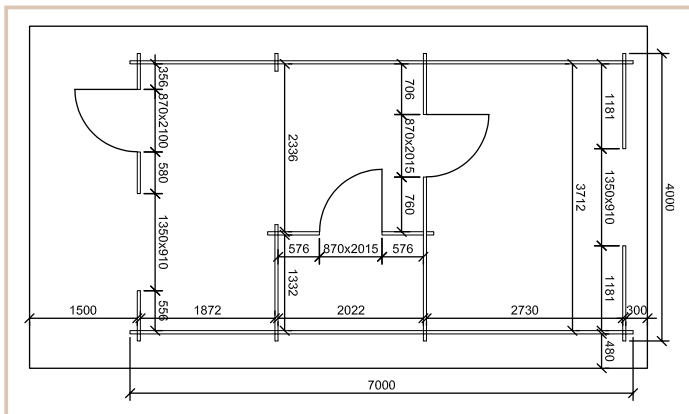

Cabin Details:

Walls	45mm
Size	4m x 7m (13.1ft x 23ft)
Doors	Premium living type doors
Windows	Premium living type windows
Roof	Steel roof tiles
Ridge height	2665mm
Wall height	2275mm
Floor bearers	50mm x 100mm

* Includes foundation cover up to 30cm + single step (width of the door).

** Add on to External wall insulation + Shiplap cladding option.

Available Upgrades:

Cabin assembly	€2,100
Timber frame & block foundation*	€1,710
100mm roof insulation	€940
Wall insulation & T&G cladding	€2,230
External wall insulation & Shiplap cladding	€2,670
Laminated flooring	€1,100
External painting (excl. paint)	€1,210
External + Internal painting (excl. paint)	€2,590
Gutters & downpipes	€510
Thermowood cladding**	€1,910

Budget One Bed D 7m x 4m



Price **€12,990**

Delivered in flatpack

Price includes:

- FREE** steel roofing tiles (value of €1060)
- FREE** damp proof membrane
- FREE** 100mm floor insulation (value of €780)
- FREE** weathering package

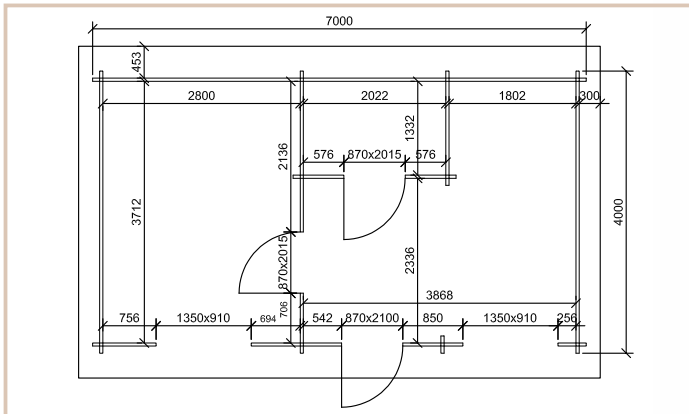

Cabin Details:

Walls	45mm
Size	7m x 4m (23ft x 13.1ft)
Doors	Premium living type doors
Windows	Premium living type windows
Roof	Steel roof tiles
Ridge height	2730mm
Wall height	2340mm
Floor bearers	50mm x 100mm

* Includes foundation cover up to 30cm + single step (width of the door).
 ** Add on to External wall insulation + Shiplap cladding option.

Available Upgrades:

Cabin assembly	€2,100
Timber frame & block foundation*	€1,710
100mm roof insulation	€790
Wall insulation & T&G cladding	€2,230
External wall insulation & Shiplap cladding	€2,670
Laminated flooring	€1,100
External painting (excl. paint)	€1,210
External + Internal painting (excl. paint)	€2,590
Gutters & downpipes	€420
Thermowood cladding**	€1,910

All visuals shown are for illustrations purposes. Actual cabin details may vary.

Budget One Bed E

6m x 5m

Price includes:

FREE steel roofing tiles
(value of €1060)

FREE damp proof
membrane

FREE 100mm floor
insulation (value of
€780)

FREE weathering
package



FREE
GERMAN MADE
'SCHÜCO' PVC
WINDOW & DOOR UPGRADE
(WHILE STOCK LAST)

Price
€15,290

Delivered in flatpack

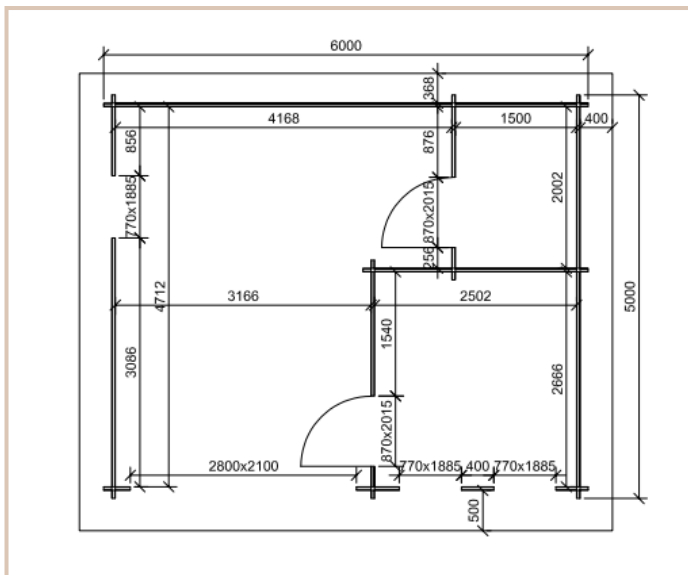

Cabin Details:

Walls	45mm
Size	6m x 5m (19.7ft x 16.4ft)
Doors	Premium living type doors
Windows	Premium living type windows
Roof	Steel roof tiles
Ridge height	2340mm
Wall height	2860mm
Floor bearers	50mm x 100mm

* Includes foundation cover up to 30cm + single step (width of the door).

** Add on to External wall insulation + Shiplap cladding option.

Available Upgrades:

Cabin assembly	€2,250
Timber frame & block foundation*	€1,830
100mm roof insulation	€830
Wall insulation & T&G cladding	€2,090
External wall insulation & Shiplap cladding	€2,750
Laminated flooring	€1,170
External painting (excl. paint)	€1,170
External + Internal painting (excl. paint)	€2,390
Gutters & downpipes	€180
Thermowood cladding**	€2,380

Budget Two Bed D 9.2m x 5.2m



FREE
GERMAN MADE
'SCHUCHO' PVC
WINDOW & DOOR UPGRADE
(WHILE STOCK LAST)



Price includes:

- FREE** steel roofing tiles (value of €2,240)
- FREE** damp proof membrane
- FREE** 100mm floor insulation (value of €1,800)
- FREE** weathering package

Price **€19,090**

Delivered in flatpack

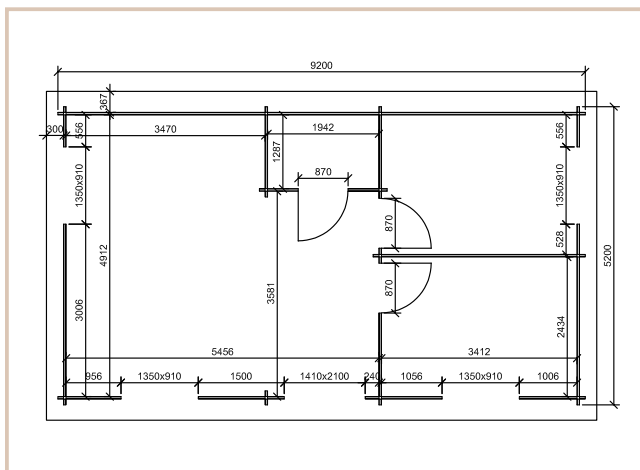

Cabin Details:

Walls	45mm / 60mm
Size	9.2m x 5.2m (30.2ft x 17ft)
Windows	Premium living type doors
Doors	Premium living type windows
Roof	Steel roof tiles
Ridge height	2665mm
Wall height	2200mm
Floor bearers	50mm x 100mm

* Includes foundation cover up to 30cm + single step (width of the door).

** Add on to External wall insulation + Shiplap cladding option.

Available Upgrades:

Cabin assembly	€3,450
Timber frame & block foundation*	€3,020
100mm roof insulation	€1,630
Wall insulation & T&G cladding	€2,820
External wall insulation & Shiplap cladding	€3,390
Laminated flooring	€1,865
External painting (excl. paint)	€1,810
External + Internal painting (excl. paint)	€3,250
Gutters & downpipes	€550
Upgrade to 60mm log	€2,000
Thermowood cladding**	€2,360



FREE
GERMAN MADE
'SCHUCO' PVC
WINDOW & DOOR UPGRADE
(WHILE STOCK LAST)



Budget Two Bed A

5.2m x 8.2m + 2.0m veranda

Price **€17,820**

Delivered in flatpack

- Price includes:**
- FREE** steel roofing tiles (value of €1,330)
 - FREE** damp proof membrane
 - FREE** 100mm floor insulation (value of €1,080)
 - FREE** weathering package

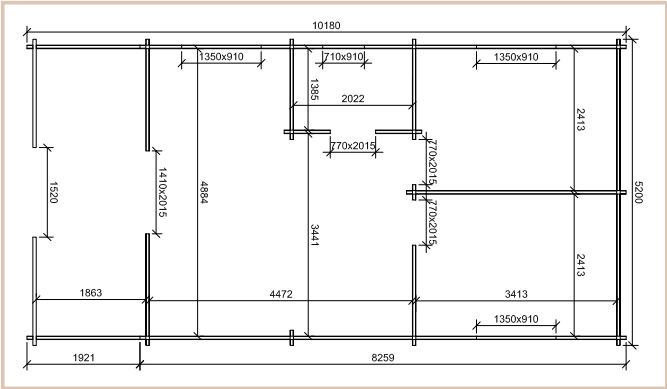

Cabin Details:

Walls	45mm / 60mm
Size	5.2m x 8.2m + 1.8m (17ft x 26.9ft + 5.9ft)
Doors	Premium living type door
Windows	Premium living type windows
Roof	Steel roof tiles
Ridge height	2665mm
Wall height	2220mm
Floor bearers	50mm x 100mm

* Includes foundation cover up to 30cm + single step (width of the door).
** Add on to External wall insulation + Shiplap cladding option.

Available Upgrades:

Cabin assembly	€3,220
Timber frame & block foundation*	€3,070
100mm roof insulation	€1,450
Wall insulation & T&G cladding	€2,570
External wall insulation & Shiplap cladding	€3,080
Laminated flooring	€1,660
External painting (excl. paint)	€1,450
External + Internal painting (excl. paint)	€2,700
Gutters & downpipes	€600
Upgrade to 60mm log	€2,050
Thermowood cladding**	€2,120

Budget Two Bed C 10m x 7m



FREE
GERMAN MADE
'SCHUCHO' PVC
WINDOW & DOOR UPGRADE
(WHILE STOCK LAST)

Price includes:

- FREE** steel roofing tiles (value of €2,240)
- FREE** damp proof membrane
- FREE** 100mm floor insulation (value of €1,800)
- FREE** weathering package



Price **€26,980**

Delivered in flatpack



Cabin Details:

Walls	45mm / 60mm
Size	10m x 7m (33.5ft x 23ft)
Windows	Premium living type doors
Doors	Premium living type windows
Roof	Steel roof tiles
Ridge height	3180mm
Wall height	2200mm
Floor bearers	50mm x 100mm

* Includes foundation cover up to 30cm + single step (width of the door).

** Add on to External wall insulation + Shiplap cladding option.

Available Upgrades:

Cabin assembly	€5,350
Timber frame & block foundation*	€4,090
100mm roof insulation	€1,820
Wall insulation & T&G cladding	€3,600
External wall insulation & Shiplap cladding	€4,330
Laminated flooring	€2,730
External painting (excl. paint)	€1,890
External + Internal painting (excl. paint)	€3,850
Gutters & downpipes	€600
Upgrade to 60mm log	€3,000
Thermowood cladding**	€3,050

Budget Three Bed A 10.2m x 7m



Price includes:

- FREE** steel roofing tiles (value of €2,240)
- FREE** damp proof membrane
- FREE** 100mm floor insulation (value of €1,800)
- FREE** weathering package

Price **€26,200**

Delivered in flatpack

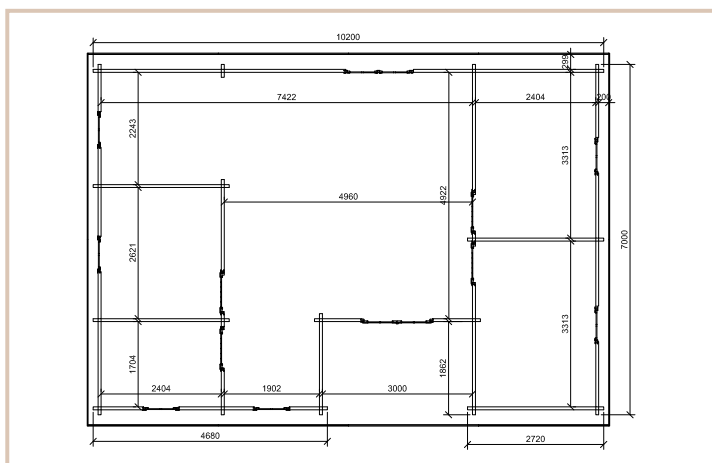

Cabin Details:

Walls	45mm / 60mm
Size	10.2m x 7m (33.5ft x 23ft)
Windows	Premium living type doors
Doors	Premium living type windows
Roof	Steel roof tiles
Ridge height	3180mm
Wall height	2350mm
Floor bearers	50mm x 100mm

* Includes foundation cover up to 30cm + single step (width of the door).

** Add on to External wall insulation + Shiplap cladding option.

Available Upgrades:

Cabin assembly	€5,350
Timber frame & block foundation*	€4,090
100mm roof insulation	€1,850
Wall insulation & T&G cladding	€3,600
External wall insulation & Shiplap cladding	€4,330
Laminated flooring	€2,785
External painting (excl. paint)	€1,800
External + Internal painting (excl. paint)	€3,750
Gutters & downpipes	€620
Upgrade to 60mm log	€3,000
Thermowood cladding**	€3,060

Budget Three Bed B 7m x 12.5m



FREE
GERMAN MADE
"SCHUCO" PVC
WINDOW & DOOR UPGRADE
(WHILE STOCK LAST)

Price
€33,100

Delivered in flatpack

Price includes:

FREE steel roofing tiles
(value of €2,550)

FREE 100mm floor
insulation (value of €2,180)

FREE damp proof membrane

FREE premium living type
windows & doors (value of
€1,800)

FREE weathering package

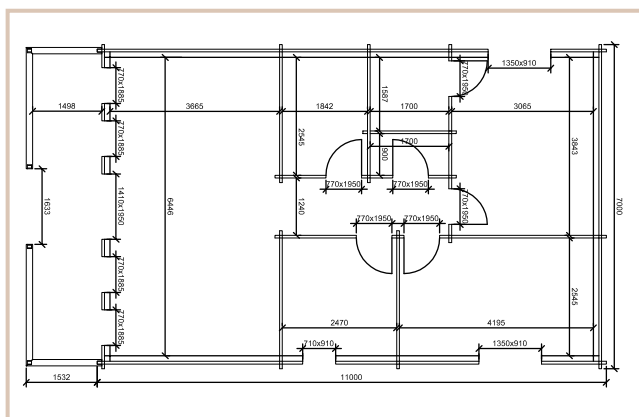

Cabin Details:

Walls	45mm / 60mm
Size	7m x 12.5m (23ft x 41ft)
Doors	Premium living type doors
Windows	Premium living type windows
Roof	Steel roof tiles
Ridge height	3185mm
Wall height	2145mm
Floor bearers	50mm x 100mm

* Includes foundation cover up to 30cm + single step (width of the door).
** Add on to External wall insulation + Shiplap cladding option.

Available Upgrades:

Cabin assembly	€5,730
Timber frame & block foundation*	€4,610
100mm roof insulation	€2,420
Wall insulation & T&G cladding	€3,920
External wall insulation & Shiplap cladding	€4,710
Laminated flooring	€3,000
External painting (excl. paint)	€1,800
External + Internal painting (excl. paint)	€3,750
Gutters & downpipes	€620
Upgrade to 60mm log	€3,000
Thermowood cladding**	€3,180

Budget Four Bed A 8m x 14m



FREE
GERMAN MADE
'SCHUCO' PVC
WINDOW & DOOR UPGRADE
(WHILE STOCK LAST)

Price
€43,800

Delivered in flatpack

Price includes:

- FREE** steel roofing tiles (value of €3,110)
- FREE** 100mm floor insulation (value of €2,800)
- FREE** damp proof membrane
- FREE** weathering package



Cabin Details:

Walls	45mm / 60mm
Size	8m x 14m (26.5ft x 46ft)
Doors	Premium living type doors
Windows	Premium living type windows
Roof	Steel roof tiles
Ridge height	3300mm
Wall height	2200mm
Floor bearers	50mm x 100mm

* Includes foundation cover up to 30cm + single step (width of the door).

** Add on to External wall insulation + Shiplap cladding option.

Available Upgrades:

Cabin Assembly	€8,500
Foundation	€POA
Roof insulation	€3,260
External wall insulation + shiplap cladding	€5,600
Laminated flooring	€4,370
External painting (excl. paint)	€2,550
External + internal painting (excl. paint)	€5,350
Gutters & downpipes	€840
Upgrade to 60mm log	€4,800
Thermowood cladding**	€4,120

Budget Four Bed B 9m x 15.5m



Price
€47,600

Delivered in flatpack

Price includes:

- FREE** steel roofing tiles (value of €3,820)
- FREE** 100mm floor insulation (value of €3,490)
- FREE** damp proof membrane
- FREE** weathering package



Cabin Details:

Walls	45mm / 60mm
Size	9m x 15.5m (29.5ft x 51ft)
Doors	Premium living type doors
Windows	Premium living type windows
Roof	Steel roof tiles
Ridge height	3500mm
Wall height	2200mm
Floor bearers	50mm x 100mm

* Includes foundation cover up to 30cm + single step (width of the door)
** Add on to External wall insulation + Shiplap cladding option.

Available Upgrades:

Cabin Assembly	€10,500
Foundation	€POA
Roof insulation	€3,500
External wall insulation + shiplap cladding	€6,240
Laminated flooring	€5,440
External painting (excl. paint)	€2,850
External + internal painting (excl. paint)	€5,850
Gutters & downpipes	€930
Upgrade to 60mm log	€5,000
Thermowood cladding**	€4,330

All visuals shown are for illustrations purposes. Actual cabin details may vary.

Dublin Studio 5m x 5m + 1m overhang



FREE
GERMAN MADE
'SCHUCO' PVC
WINDOW & DOOR UPGRADE
(WHILE STOCK LAST)



Price **€14,100**

Delivered & assembled

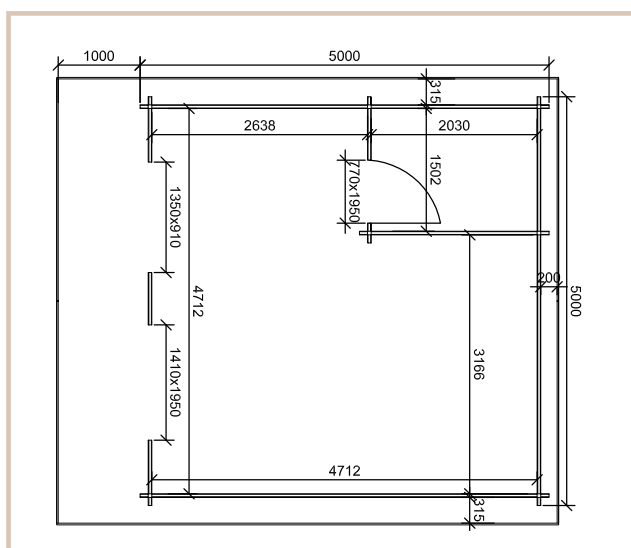

Price includes:

FREE steel roof tiles (€860)

FREE 100mm floor and roof insulation (€1,400)

FREE weathering package

Cabin Details:

Wall thickness	45mm
Size	5m x 5m (16.4ft x 16.4ft)
Doors	Premium living type doors
Windows	Premium living type windows
Roof	Steel roof tiles
Ridge height	2535mm
Wall height	2145mm
Floor bearers	50mm x 100mm

* Includes foundation cover up to 30cm + single step (width of the door).

** Add on to External wall insulation + Shiplap cladding option.

Available Upgrades:

Timber frame & block foundation*	€1,650
Wall insulation & T&G cladding	€1,980
External wall insulation & Shiplap cladding	€2,370
Laminated flooring	€975
External painting (excl. paint)	€850
External + Internal painting (excl. paint)	€1,700
Upgrade to steel roof	€810
Gutters & downpipes	€360
Veranda	€350
Thermowood cladding**	€1,650

One Bed Type C 5.8m x 5m



FREE
GERMAN MADE
'SCHUCO' PVC
WINDOW & DOOR UPGRADE
(WHILE STOCK LAST)



Price
€15,830

Delivered &
assembled

Price includes:
FREE 100mm floor and
roof insulation (€1,510)
FREE steel roof upgrade (€810)
FREE weathering package

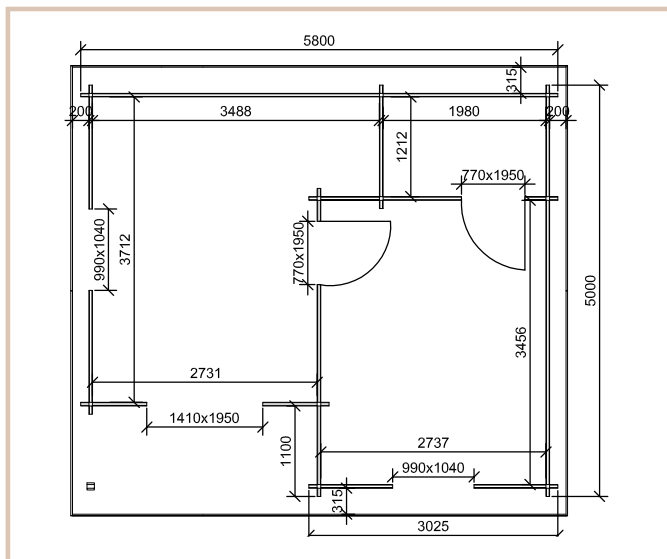

Cabin Details:

Wall thickness	45mm
Size	5.8m x 5m (19ft x 16.4ft)
Doors	Premium living type doors
Windows	Premium living type windows
Roof	Steel roof tiles
Ridge height	2600mm
Wall height	2210mm
Floor bearers	50mm x 100mm

Available Upgrades:

Timber frame & block foundation*	€1,750
Wall insulation & T&G cladding	€2,190
External wall insulation & Shiplap cladding	€2,630
Laminated flooring	€1,015
External painting (excl. paint)	€1,210
External + Internal painting (excl. paint)	€2,590
Gutters & downpipes	€360
Thermowood cladding**	€1,800

* Includes foundation cover up to 30cm + single step (width of the door) ** Add on to External wall insulation + Shiplap cladding option.

All visuals shown are for illustrations purposes. Actual cabin details may vary.

One Bed Type E 5.0m x 5.8m + 1.5m veranda



FREE
GERMAN MADE
"SCHUCO" PVC
WINDOW & DOOR UPGRADE
(WHILE STOCK LAST)



Price
€16,400

Delivered &
assembled

Price
includes:

FREE 100mm
floor and roof
insulation
(€1,510)

FREE steel roof
upgrade (€810)

FREE weathering
package

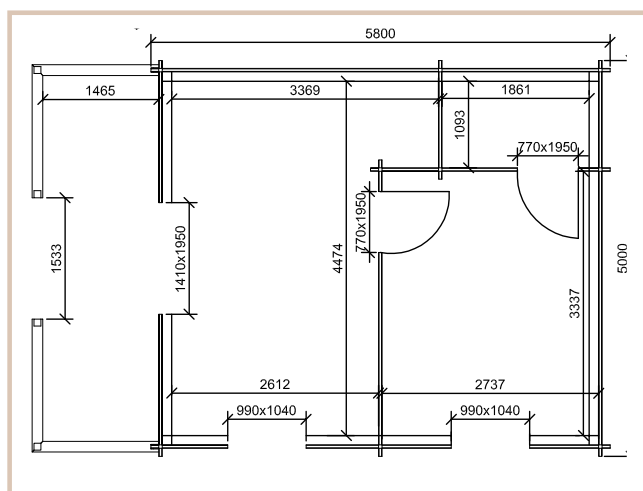

Cabin Details:

Wall thickness	45mm
Size	5.0m x 5.8m + 1.5m (16.4ft x 19ft +5ft)
Doors	Premium living type doors
Windows	Premium living type windows
Roof	Steel roof tiles
Ridge height	2600mm
Wall height	2210mm
Floor bearers	50mm x 100mm

Available Upgrades:

Timber frame & block foundation*	€2,180
Wall insulation & T&G cladding	€2,190
External wall insulation & Shiplap cladding	€2,630
Laminated flooring	€1,130
External painting (excl. paint)	€1,330
External + Internal painting (excl. paint)	€2,650
Gutters & downpipes	€440
Thermowood cladding**	€1,800

* Includes foundation cover up to 30cm + single step (width of the door) ** Add on to External wall insulation + Shiplap cladding option.

One Bed Type D 5.8m x 5m



Price
€16,200

Delivered & assembled

Price includes:
FREE 100mm floor and roof insulation (€1,510)
FREE steel roof upgrade (€810)
FREE weathering package

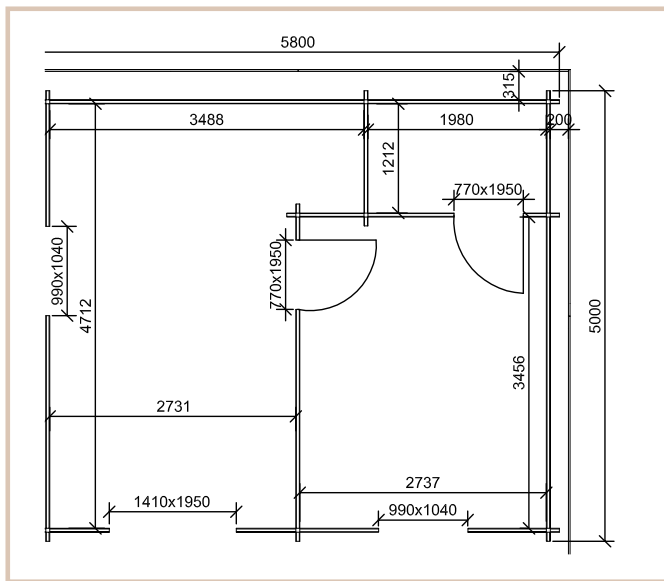

Cabin Details:	
Wall thickness	45mm
Size	5.8m x 5m (19ft x 16.4ft)
Doors	Premium living type doors
Windows	Premium living type windows
Roof	Steel roof tiles
Ridge height	2600mm
Wall height	2210mm
Floor bearers	50mm x 100mm

Available Upgrades:	
Timber frame & block foundation*	€1,760
Wall insulation & T&G cladding	€2,190
External wall insulation & Shiplap cladding	€2,630
Laminated flooring	€1130
External painting (excl. paint)	€1,210
External + Internal painting (excl. paint)	€2,590
Gutters & downpipes	€360
Thermowood cladding**	€1,800

* Includes foundation cover up to 30cm + single step (width of the door) ** Add on to External wall insulation + Shiplap cladding option.

All visuals shown are for illustrations purposes. Actual cabin details may vary.



FREE
GERMAN MADE
'SCHUCO' PVC
WINDOW & DOOR UPGRADE
(WHILE STOCK LAST)



Loft Log Cabin A

4.5m x 6m

Price
€19,270

Delivered & assembled

Price includes:

- FREE** assembly
- FREE** steel roof upgrade (€860)
- FREE** 100mm floor and roof insulation (€1,520)
- FREE** weathering package

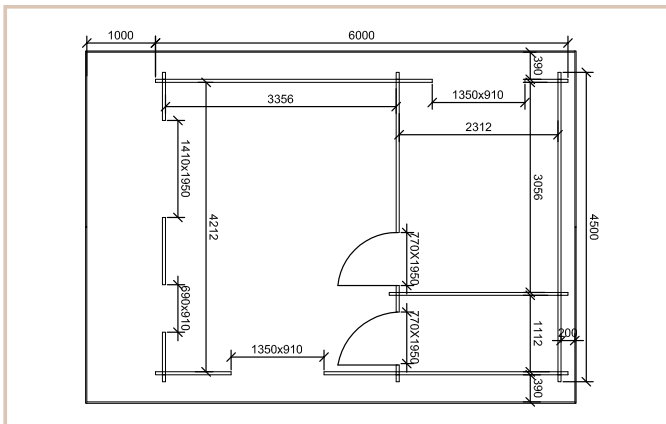

Cabin Details:

Wall thickness	45mm
Overall Size	4.5m x 7m (14.8ft x 23ft)
Doors	Premium living type doors
Windows	Premium living type windows
Roof	Steel roof tiles
Ridge height	3705mm
Wall height	2535mm
Floor bearers	50mm x 100mm

Available Upgrades:

Timber frame & block foundation*	€2,000
Wall insulation & T&G cladding	€2,650
External wall insulation & Shiplap cladding	€3,050
External painting (excl. paint)	€1,740
External + Internal painting (excl. paint)	€3,740
Gutters & downpipes	€420
Thermowood cladding**	€2,800

* Includes foundation cover up to 30cm + single step (width of the door)
** Add on to External wall insulation + Shiplap cladding option.



Two Bed Type D

6m x 6m

Price
€22,270

Delivered & assembled

Price includes:

FREE assembly

FREE steel roof upgrade (€1,090)

FREE 100mm floor and roof insulation (€1,960)

FREE weathering package

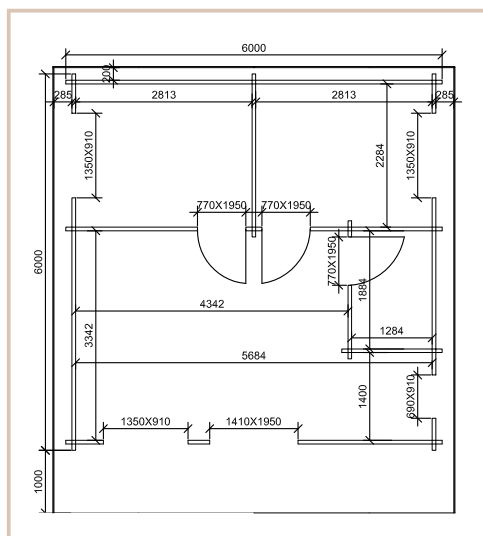

Cabin Details:

Wall thickness	45mm / 60mm
Size	6m x 6m (19.7ft x 19.7ft)
Doors	Premium living type doors
Windows	Premium living type windows
Roof	Steel roof tiles
Ridge height	2925mm
Wall height	2145mm
Floor bearers	50mm x 100mm

* Includes foundation cover up to 30cm + single step (width of the door)

** Add on to External wall insulation + Shiplap cladding option.

Available Upgrades:

Timber frame & block foundation	€2,160
Wall insulation & T&G cladding	€2,450
External wall insulation & Shiplap cladding	€2,940
Laminated flooring	€1,405
External painting (excl. paint)	€1,600
External + Internal painting (excl. paint)	€3,340
Gutters & downpipes	€420
Upgrade to 60mm log	€1,700
Thermowood cladding**	€2,010

Two Bed Type E 6m x 7.5m



FREE
GERMAN MADE
'SCHUCO' PVC
WINDOW & DOOR UPGRADE
(WHILE STOCK LAST)



Price
€25,100
Delivered & assembled

Price includes:
FREE assembly
FREE steel roof upgrade
FREE 100mm floor & roof insulation
FREE weathering package

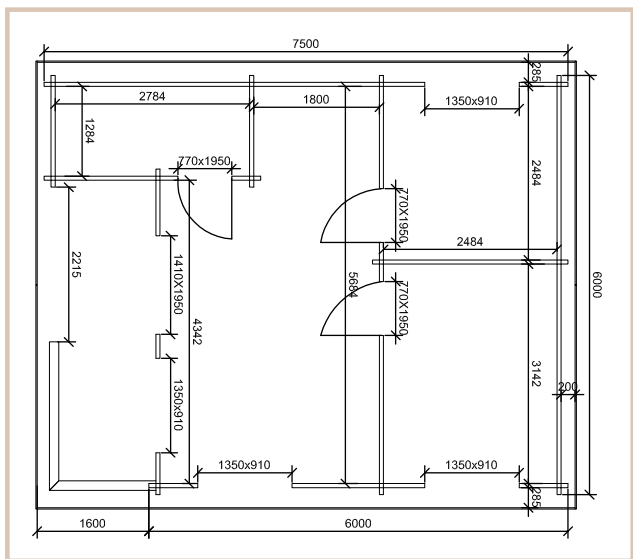

Cabin Details:

Wall thickness	45mm / 60mm
Size	6m x 7.5m (19.7ft x 24.6ft)
Doors	Premium living type doors
Windows	Premium living type windows
Roof	Steel roof tiles
Ridge height	2925mm
Wall height	2145mm
Floor bearers	50mm x 100mm

Available Upgrades:

Timber frame & block foundation	€2,660
Wall insulation & T&G cladding	€2,760
External wall insulation & Shiplap cladding	€3,300
Laminated flooring	€1,505
External painting (excl. paint)	€1,800
External + Internal painting (excl. paint)	€3,740
Gutters & downpipes	€450
Upgrade to 60mm log	€1,850
Thermowood cladding**	€2,300

* Includes foundation cover up to 30cm + single step (width of the door). ** Add on to External wall insulation + Shiplap cladding option.



FREE
GERMAN MADE
"SCHUCO" PVC
WINDOW & DOOR UPGRADE
(WHILE STOCK LAST)



Two Bed Type C

6m x 8m + 1.5m veranda

Price
€28,350

Delivered & assembled

Price includes:

FREE steel roof upgrade (€1,520)

FREE 100mm floor and roof insulation (€2,680)

FREE weathering package

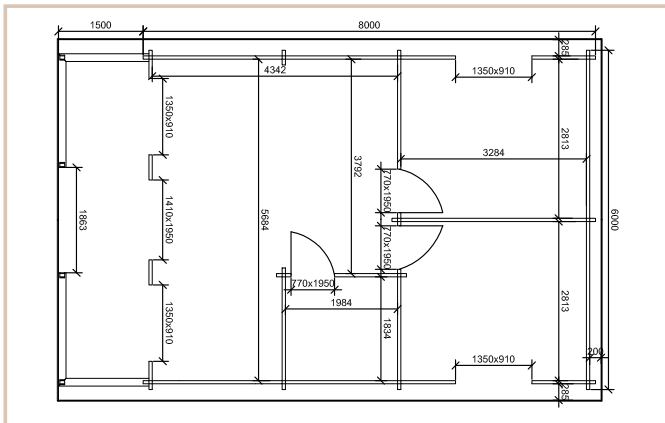

Cabin Details:

Wall thickness	45mm / 60mm
Size	6m x 9.5m (19.7ft x 31.2ft)
Doors	Premium living type doors
Windows	Premium living type windows
Roof	Steel roof tiles
Ridge height	2925mm
Wall height	2145mm
Floor bearers	50mm x 100mm

Available Upgrades:

Timber frame & block foundation*	€2,780
Wall insulation & T&G cladding	€2,890
External wall insulation & Shiplap cladding	€3,460
Laminated flooring	€1,870
External painting (excl. paint)	€1,890
External + Internal painting (excl. paint)	€3,850
Gutters & downpipes	€570
Upgrade to 60mm log	€2,100
Thermowood cladding**	€2,300

* Includes foundation cover up to 30cm + single step (width of the door). ** Add on to External wall insulation + Shiplap cladding option.

All visuals shown are for illustrations purposes. Actual cabin cabin details may vary.



Two Bed Type F

6m x 9.5m + 1.5m veranda

Price
€30,850

Delivered & assembled

Price includes:
FREE steel roof upgrade (€1,830)
FREE 100mm floor and roof insulation (€3,220)
FREE weathering package

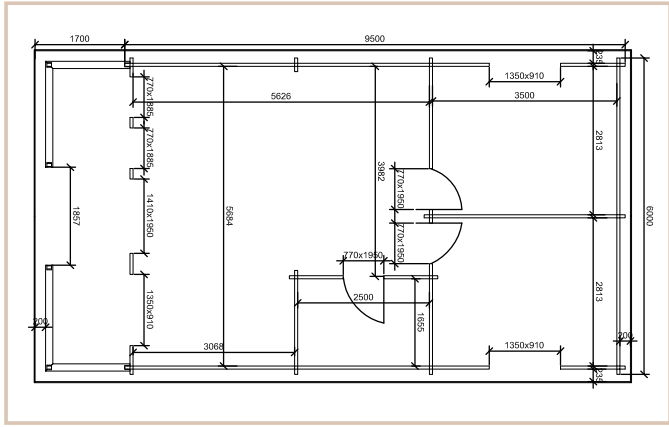

Cabin Details:

Wall thickness	45mm / 60mm
Size	6m x 11m (19.7ft x 36ft)
Doors	Premium living type doors
Windows	Premium living type windows
Roof	Steel roof tiles
Ridge height	2925mm
Wall height	2145mm
Floor bearers	50mm x 100mm

Available Upgrades:

Timber frame & block foundation*	€3,250
Wall insulation & T&G cladding	€3,190
External wall insulation & Shiplap cladding	€3,830
Laminated flooring	€2,225
External painting (excl. paint)	€2,670
External + Internal painting (excl. paint)	€4,540
Gutters & downpipes	€660
Upgrade to 60mm log	€2,250
Thermowood cladding**	€2,640

* Includes foundation cover up to 30cm + single step (width of the door). ** Add on to External wall insulation + Shiplap cladding option.

Three Bed Type A 7m x 11m + 1.5m veranda



FREE
GERMAN MADE
SCHUCO PVC
WINDOW & DOOR UPGRADE
(WHILE STOCK LAST)



Price includes:

- FREE** assembly
- FREE** steel roof upgrade (€2,300)
- FREE** weathering package
- FREE** 100mm floor and roof insulation (€4,200)

Price
€40,110
Delivered & assembled

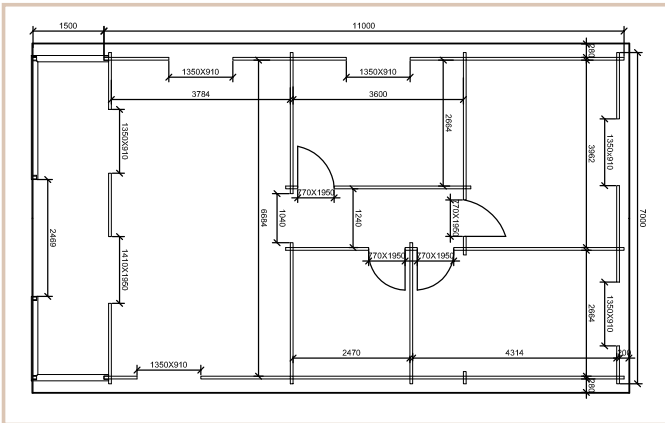

Cabin Details:

Wall thickness	45mm / 60mm
Size	7m x 12.5m (23ft x 41ft)
Doors	Premium living type doors
Windows	Premium living type windows
Roof	Steel roof tiles
Ridge height	3185mm
Wall height	2145mm
Floor bearers	50mm x 100mm

Available Upgrades:

Timber frame & block foundation*	€4,610
Wall insulation & T&G cladding	€3,920
External wall insulation & Shiplap cladding	€4,710
Laminated flooring	€3,005
External painting (excl. paint)	€2,400
External + Internal painting (excl. paint)	€5,070
Gutters & downpipes	€750
Upgrade to 60mm log	€3,200
Thermowood cladding**	€3,180

* Includes foundation cover up to 30cm + single step (width of the door). ** Add on to External wall insulation + Shiplap cladding option.

All visuals shown are for illustration purposes. Actual cabin details may vary.



FREE
GERMAN MADE
'SCHÜCO' PVC
WINDOW & DOOR UPGRADE
(WHILE STOCK LAST)



Three Bed Type B

6m x 11m

Price
€36,100

Delivered & assembled

Price includes:

FREE damp proof membrane

FREE steel roof upgrade (€1,750)

FREE 100mm floor and roof insulation (€3,320)

FREE weathering package

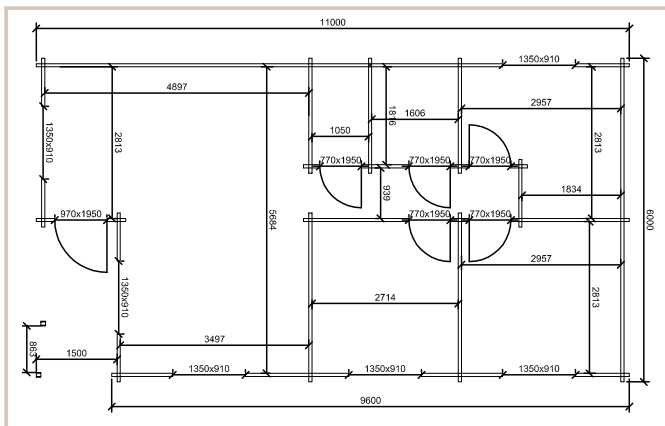

Cabin Details:

Walls	45mm / 60mm
Size	6m x 11m (19.7ft x 36ft)
Doors	Premium living type doors
Windows	Premium living type windows
Roof	Steel roof tiles
Ridge height	2925mm
Wall height	2145mm
Floor bearers	45mm x 100mm

* Includes foundation cover up to 30cm + single step (width of the door).

** Add on to External wall insulation + Shiplap cladding option.

Available Upgrades:

Timber frame & block foundation*	€3,250
Wall insulation & T&G cladding	€3,500
External wall insulation & Shiplap cladding	€4,200
Laminated flooring	€2,575
External painting (excl. paint)	€2,400
External + Internal painting (excl. paint)	€5,070
Upgrade to steel roof	Included
Cutters & downpipes	€660
Upgrade to 60mm log	€2,500
Thermowood cladding**	€2,720



Four Bed Type A

8m x 12m + 1.5m veranda

Price
€49,800

Delivered & assembled

Price includes:

FREE assembly

FREE steel roof upgrade (€2,700)

FREE 100mm floor and roof insulation (€5,100)

FREE weathering package

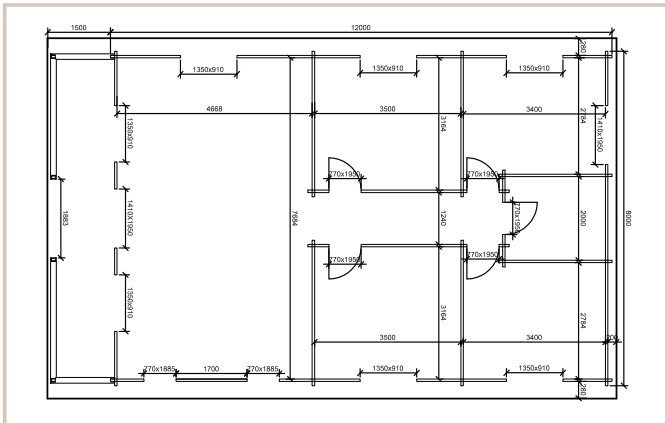

Cabin Details:

Wall thickness	60mm / 70mm Glulam
Size	8m x 13.5m (26ft x 39ft)
Doors	Premium living type doors
Windows	Premium living type windows
Roof	Steel roof tiles
Ridge height	3185mm
Wall height	2145mm
Floor bearers	50mm x 100mm

Available Upgrades:

Timber frame & block foundation	€5,200
Wall insulation & T&G cladding	€4,400
External wall insulation & Shiplap cladding	€5,280
Laminated flooring	€3,745
External painting (excl. paint)	€3,050
External + Internal painting (excl. paint)	€5,800
Gutters & downpipes	€810
Upgrade to 60mm log	€2,500
Thermowood cladding**	€3,390

Includes foundation cover up to 30cm + single step (width of the door). ** Add on to External wall insulation + Shiplap cladding option.

All visuals shown are for illustration purposes. Actual cabin details may vary.

WWW.LOGHOUSE.IE [f/LOGHOUSE.IE](https://www.facebook.com/LOGHOUSE.IE)

Glamping Pods

Price includes:
FREE shingle roof tiles

FREE damp proof membrane
FREE 50mm floor insulation

FREE weathering package
FREE delivery in Leinster Area

3m x 3m Price **€4,930**

3m x 4m Price **€5,710**



Available Upgrades:

Pod Assembly	€720
Timber frame and block pad foundation	€630
Laminate Flooring	€350

Available Upgrades:

Pod Assembly	€960
Timber frame and block pad foundation	€840
Laminate Flooring	€470

3m x 5m Price **€7,710**

3m x 6m Price **€8,430**



Available Upgrades:

Pod Assembly	€1,200
Timber frame and block pad foundation	€970
Laminate Flooring	€585

Available Upgrades:

Pod Assembly	€1,440
Timber frame and block pad foundation	€1,130
Laminate Flooring	€700

Price includes:
FREE shingle roof tiles

FREE damp proof membrane
FREE 50mm floor insulation

FREE weathering package
FREE delivery in Leinster Area

4m x 6m

Price **€10,180**



FREE
 GERMAN MADE
 SCHUCO® PVC
 WINDOW & DOOR UPGRADE
 (WHILE STOCK LAST)



4m x 8m One Bed A

Price **€12,630**



FREE
 GERMAN MADE
 SCHUCO® PVC
 WINDOW & DOOR UPGRADE
 (WHILE STOCK LAST)



Available Upgrades:

Pod Assembly	€1,800
Timber frame and block pad foundation	€1,460
Laminate Flooring	€935



Available Upgrades:

Pod Assembly	€2,400
Timber frame and block pad foundation	€1,950
Laminate Flooring	€1,250

4m x 8m One Bed B

Price **€12,940**



FREE
 GERMAN MADE
 SCHUCO® PVC
 WINDOW & DOOR UPGRADE
 (WHILE STOCK LAST)



4m x 10m Two Bed

Price **€15,080**



FREE
 GERMAN MADE
 SCHUCO® PVC
 WINDOW & DOOR UPGRADE
 (WHILE STOCK LAST)



Available Upgrades:

Pod Assembly	€2,400
Timber frame and block pad foundation	€1,950
Laminate Flooring	€1,250



Available Upgrades:

Pod Assembly	€3,000
Timber frame and block pad foundation	€2,400
Laminate Flooring	€1,560

Saunas

2.5m Mini Sauna | Price €5,290



Available Upgrades:	
Sauna Assembly	Included
Timber frame and block pad foundation	Included
Round Glass	€900
Half Glass	€500
Wood Stove	€650
External painting (excl. paint)	€450
Thermowood cladding	€750



3.0m Midi Sauna | Price €5,840



Available Upgrades:	
Sauna Assembly	Included
Timber frame and block pad foundation	Included
Round Glass	€900
Half Glass	€500
Wood Stove	€650
External painting (excl. paint)	€450
Thermowood cladding	€960



Sauna Features:

- ✓ Electric Harvia 9kw stove
- ✓ Sauna stones

- ✓ Black Alder benches
- ✓ Tempered glass doors
- ✓ Shingle tile roof

- ✓ Stainless steel tightening hoops
- ✓ Tempered glass doors
- ✓ **FREE delivery in Leinster Area**

4.0m Maxi Sauna | Price €6,930



Available Upgrades:

Sauna Assembly	Included
Timber frame and block pad foundation	Included
Round Glass	€900
Half Glass	€500
Wood Stove	€650
External painting (excl. paint)	€750
Thermowood cladding	€1,230



6.0m Grande Sauna | Price €8,690



Available Upgrades:

Sauna Assembly	Included
Timber frame and block pad foundation	Included
Round Glass	€900
Half Glass	€500
Wood Stove	€650
External painting (excl. paint)	€750
Thermowood cladding	€1,660



Two, Three & Four Bedroom Contemporary Log Cabins



Two Bed 13.7m x 8.2m (44.9ft x 27ft) Price **€74,690**

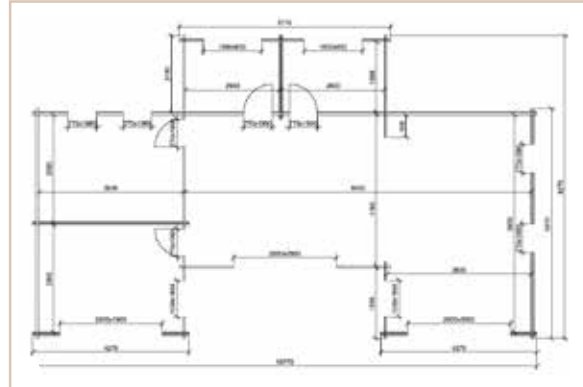

Three Bed 10.7m x 9.2m (35.1ft x 30.2ft) Price **€75,190**

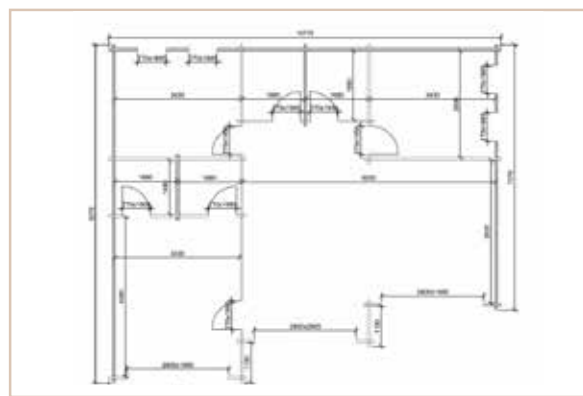

Four Bed 14.2m x 12.2m (46.5ft x 40ft) Price **€96,190**

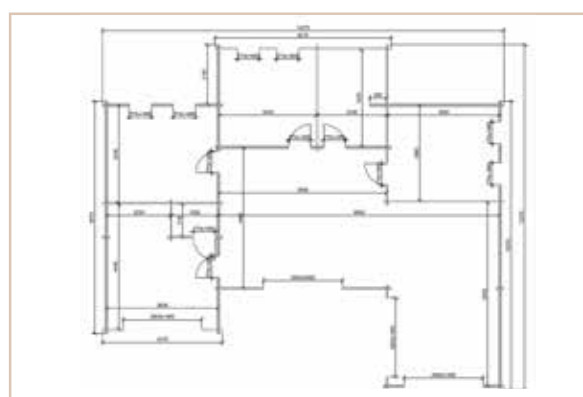

Price includes:		Available Upgrades:	
Professional assembly service	Roof insulation	Foundation screws	from €90 per m ²
60mm solid log walls.	Premium, Glue-laminated windows & doors	Concrete foundations	P.O.A
Floor insulation	Tile effect steel roof	70mm Glue-laminated log walls	P.O.A
Wall insulation + T&G cladding	Gutters & downpipes.	External wall insulation & shiplap cladding	P.O.A
		Professional painting service	P.O.A
		Thermowood cladding**	P.O.A

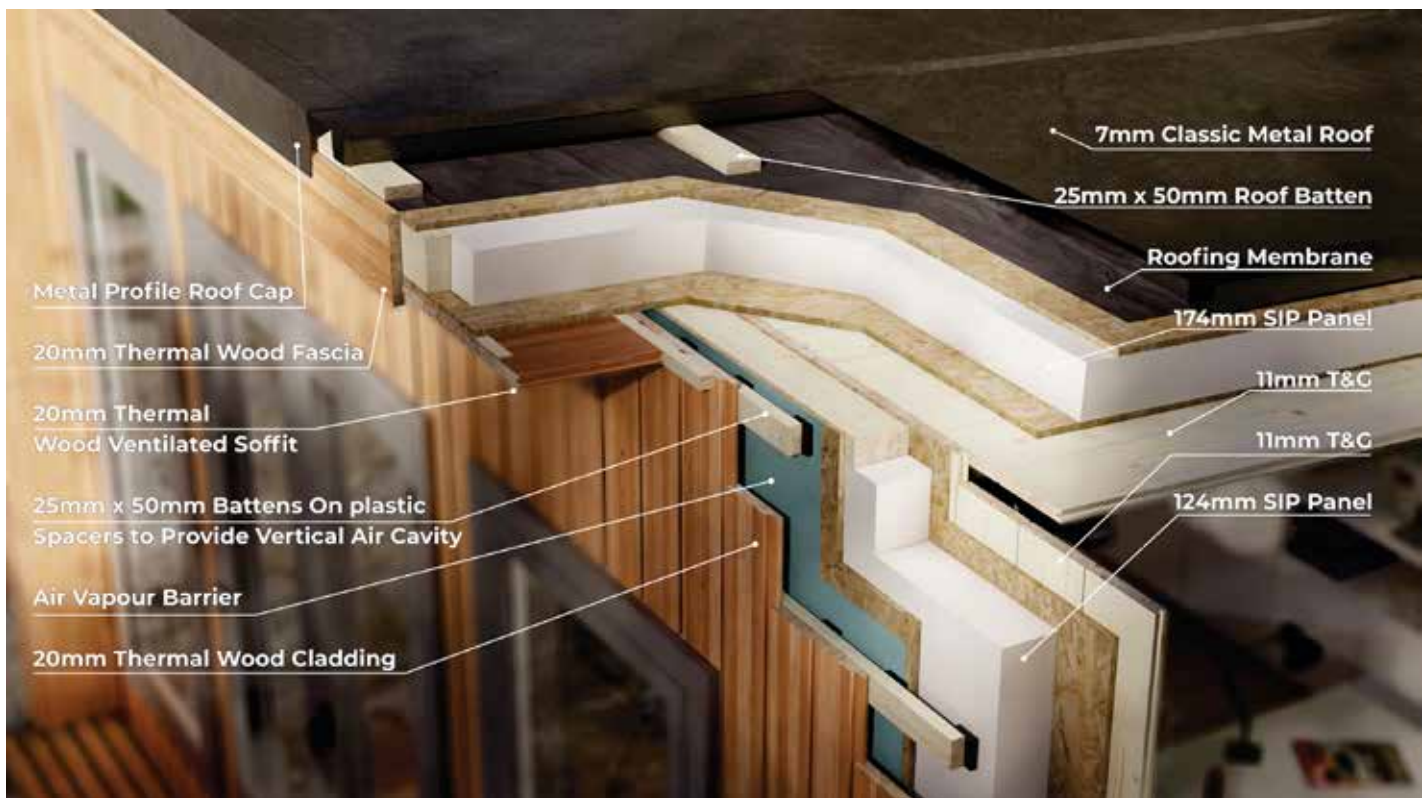

3.0m x 3.3m Price **€13,199**



FREE
GERMAN MADE
SCHÜCO® PVC
WINDOW & DOOR UPGRADE
(WHILE STOCK LAST)



Exterior oiling (incl. oil)
4.2m x 3.4m € 560; 4.2m x 4.4m €660

Room Details

EPS Insulated (150mm) roof total thickness	217mm
EPS Insulated (100mm) walls total thickness	184mm
Size	3.0m x 3.3m (9.8ft x 10.8ft)
Frame & Foundations	Ground-screws foundation
Flooring	Laminate
Flooring Insulation	EPS 100mm
Windows & Doors	Grey uPVC, double glazed
External Cladding	THERMO WOOD
Roofing System	Grey Insulated Classic Metal
Internal Cladding	11mm T&G
Gutters & Downpipes	Included

4.2m x 3.4m Price **€18,069** | 4.2m x 4.4m Price **€20,149**



FREE
GERMAN MADE
SCHÜCO® PVC
WINDOW & DOOR UPGRADE
(WHILE STOCK LAST)



Exterior oiling (incl. oil)
4.2m x 3.4m € 560; 4.2m x 4.4m €660

Room Details

EPS Insulated (150mm) roof total thickness	217mm
EPS Insulated (100mm) walls total thickness	184mm
Size	4.2m x 3.4m (13.7ft x 11.1ft) 4.2m x 4.4m (13.7ft x 14.4ft)
Frame & Foundations	Ground-screws foundation
Flooring	Laminate
Flooring Insulation	EPS 100mm
Windows & Doors	Grey uPVC, double glazed
External Cladding	THERMO WOOD
Roofing System	Grey Insulated Classic Metal
Internal Cladding	11mm T&G
Gutters & Downpipes	Included

5.2m x 3.4m Price **€19,049** | 5.2m x 4.4m Price **€22,199**



FREE
GERMAN MADE
SCHÜCO® PVC
WINDOW & DOOR UPGRADE
(WHILE STOCK LAST)



Exterior oiling (incl. oil)
5.2m x 3.4m € 640; 5.2m x 4.4m €760

Room Details

EPS Insulated (150mm) roof total thickness	217mm
EPS Insulated (100mm) walls total thickness	184mm
Size	5.2m x 4.4m (17.1ft x 14.4ft) 5.2m x 3.4m (17.1ft x 11.1ft)
Frame & Foundations	Ground-screws foundation
Flooring	Laminate
Flooring Insulation	EPS 100mm
Windows & Doors	Grey uPVC, double
External Cladding	THERMO WOOD
Roofing System	Grey Insulated Classic Metal
Internal Cladding	11mm T&G
Gutters & Downpipes	Included

6.2m x 3.4m Price **€21,099** | 6.2m x 4.4m Price **€24,179**



FREE
GERMAN MADE
SCHÜCO® PVC
WINDOW & DOOR UPGRADE
(WHILE STOCK LAST)



Exterior oiling (incl. oil)
6.2m x 3.4m € 720; 6.2m x 4.4m €860

Room Details

EPS Insulated (150mm) roof total thickness	217mm
EPS Insulated (100mm) walls total thickness	184mm
Size	6.2m x 4.4m (20.3ft x 14.4ft) 6.2m x 3.4m (20.3ft. x 11.1ft)
Frame & Foundations	Ground-screws foundation
Flooring	Laminate
Flooring Insulation	EPS 100mm
Windows & Doors	Grey uPVC, double
External Cladding	THERMO WOOD
Roofing System	Grey Insulated Classic Metal
Internal Cladding	11mm T&G
Gutters & Downpipes	Included

Studio Eco Garden Room



FREE
GERMAN MADE
'SCHUCO' PVC
WINDOW & DOOR UPGRADE
(WHILE STOCK LAST)

5.0m x 4.0m Price **€24,999**

6.0m x 4.0m Price **€27,499**

Room Details

EPS Insulated (150mm) roof total thickness	217mm
EPS Insulated (100mm) walls total thickness	184mm
Size	5.0m x 4.0m (16.4ft x 13.1ft) 6.0m x 4.0m (19.6ft x 13.1ft)
Wall Height	2,200mm
Ridge Height	2900mm/3200mm
Frame & Foundations	Ground-screws foundation
Flooring	Laminate
Flooring Insulation	EPS 100mm
Windows & Doors	Grey uPVC, double
External Cladding	THERMO WOOD
Roofing System	Grey Insulated Classic Metal
Internal Cladding	11mm T&G
Gutters & Downpipes	Included
External painting (incl. oil)	€760/ €860
External + Internal painting (Internal & external (incl. oil and internal paint/stain)	€1,420/ €1,620



One Bed Eco Garden Room

5.3m x 7.5m



FREE
GERMAN MADE
"SCHUCO" PVC
WINDOW & DOOR UPGRADE
(WHILE STOCK LAST)

Price **€39,999**

Room Details

EPS Insulated (150mm) roof total thickness	217mm
EPS Insulated (100mm) walls total thickness	184mm
Size	5.3m x 7.5m (17.3ft x 24.6ft)
Wall Height	2200mm
Ridge Height	2900mm
Frame & Foundations	Ground-screws foundation
Flooring	Laminate
Flooring Insulation	EPS 100mm
Windows & Doors	Grey uPVC, double
External Cladding	THERMO WOOD
Roofing System	Grey Insulated Classic Metal
Internal Cladding	11mm T&G
Gutters & Downpipes	Included



External painting (incl. oil)	€1,150
External + Internal painting (Internal & external (incl. oil and internal paint/stain))	€2,650

Two Bed Eco Garden Room

6.0m x 11.0m



FREE
GERMAN MADE
'SCHUCO' PVC
WINDOW & DOOR UPGRADE
(WHILE STOCK LAST)

Price **€58,499**

Room Details

EPS Insulated (150mm) roof total thickness	217mm
EPS Insulated (100mm) walls total thickness	184mm
Size	6.0m x 11.0m (19.7ft x 36.1ft)
Wall Height	2200mm
Ridge Height	3100mm
Frame & Foundations	Ground-screws foundation
Flooring	Laminate
Flooring Insulation	EPS 100mm
Windows & Doors	Grey uPVC, double
External Cladding	THERMO WOOD
Roofing System	Grey Insulated Classic Metal
Internal Cladding	11mm T&G
Gutters & Downpipes	Included



External painting (incl. oil) **€2,300**

External + Internal painting
(Internal & external (incl. oil and internal paint/stain)) **€4,950**

Three Bed Eco Garden Room

7.0m x 12.5m



FREE
GERMAN MADE
"SCHUCO" PVC
WINDOW & DOOR UPGRADE
(WHILE STOCK LAST)

Price **€74,499**

Room Details

EPS Insulated (150mm) roof total thickness	217mm
EPS Insulated (100mm) walls total thickness	184mm
Size	7.0m x 12.5m (23.0ft x 41.0ft)
Wall Height	2200mm
Ridge Height	3100mm
Frame & Foundations	Ground-screws foundation
Flooring	Laminate
Flooring Insulation	EPS 100mm
Windows & Doors	Grey uPVC, double
External Cladding	THERMO WOOD
Roofing System	Grey Insulated Classic Metal
Internal Cladding	11mm T&G
Gutters & Downpipes	Included



External painting (incl. oil) **€3,150**

External + Internal painting
(Internal & external (incl. oil
and internal paint/stain) **€6,550**

‘Bespoke’ Products

At Loghouse.ie, we offer a “bespoke” or custom design service to tailor all our pre-engineered models to your needs or start from scratch with your own idea with help from our highly qualified team of planners and log cabin experts, we will

guide you through the design process.

Our staff can provide working drawings, three dimensional renderings and technical specifications to suit your specific design so you can “visualise it” in real time before it is even built.

Extensions

Whether you are adding one small room or doubling the size of your house we offer a comprehensive, professional service and competitive pricing. We specialise in building your dream home, extension, sunroom or porch with matching materials, making the

extensions look part of your original house.

If you wish to make home improvements, below is a quick checklist of services and a list of upgrades that we can bring to your home.

Extensions, at a glance...

- A rated
- Fully insulated timber frame extensions
- Our in house design available to discuss your needs
- Quick on site assembly
- Double / triple glazed windows and doors
- Exterior can be rendered or timber cladded
- Internally, plasterboard or timber finish
- Planning arranged if needed

Guide Price

€850 sq/m
€80 sq/ft

Delivered & Fitted

Price Includes...

- Building delivered and fitted
- Fully insulated
- Walls 45+100+19mm
- Total wall thickness 164mm
- 100mm roof insulation
- 100mm floor insulation
- Living type windows and doors
- Steel roof

Priced on site:

- Foundation
- Connecting to main house
- Plumbing
- Kitchens
- Electrics
- Painting



Log Cabin Mobile Homes

A lot of people nowadays spend their life travelling all over the world - if you are such a person and tourism is your life, choose the mobile home that suits your needs. Mobile homes can be like usual homes people live in, fitted with everything needed for living: electricity, furniture, kitchen and other utilities. Mobile homes are a cost effective

alternative (even if it is a permanent structure).

All our mobile home log cabin designs can be fully customised to meet your needs. Please fill in the details of your bespoke ideas, use our sketch pad, or alternatively attach a plan or photo to help us better understand what you would like to do.

Mobile Homes, at a glance...

- Designed for holiday parks and temporary accommodation
- Can be moved in one piece
- A Rated
- Double / triple glazed windows
- LED lighting
- Smart heating systems
- Affordable



Guide Price

€950 sq/m

€90 sq/ft

Delivered & Fitted

Price Includes

- Building delivered and fitted
- Fully insulated
- Walls 60+100+19mm
- Total wall thickness 179mm
- 100mm roof insulation
- 100mm floor insulation
- Living type windows and doors
- Steel roof

Priced on site:

- Foundation
- Connecting to main house
- Plumbing
- Kitchens
- Electrics
- Painting



For perfect results Loghouse recommends **Vivacolor & Tikkurila** Paint & Stains Range

€130 / 9Ltr Bucket

€40 / 2.7Ltr Bucket (2661 & 2686 only)

For more information and painting quotations please contact our partners at: 085 - 874 2629, 085 - 862 1972 or email: info@ekdecor.ie



Paint



2661

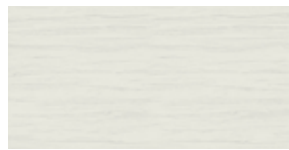

2686



2688



5060



2685



2682



2680



5052



2664



435



568



5077

Stains

Wall Make up Detail



Completed Projects

1 Bed Log Cabin



2 Bed Log Cabin



3 Bed Log Home



4 Bed Log Cabin



Home Office Log Cabin



Eco Garden Rooms



Home Gym Log Cabin



Extension Log Cabin



Mobile Home



Pre-School Log Cabin



Visit one of our **5 showrooms** to view the extensive range of our products and services.

Dublin North Showroom

Tue – Sat: 12 – 5pm,
Sun & Mon: Closed



Kinsealy Garden Centre
Malahide Road,
Kinsealy, Dublin D17 XD86
Tel: 01 – 201 7675
Mob: 085 – 805 0733
Email: martin@loghouse.ie

Dublin South Showroom

7 Days a week: 12 – 5pm



Horkans Garden Centre
Glen of the Downs
Bray, Co Wicklow A98 W3V8
Tel: 01 – 201 7675
Mob: 087 – 465 4750
Email: aaron@loghouse.ie

Loghouse Factory Warehouse Residential Only

Mon – Fri:
By appointment only



Unit 518A, Grants Crescent
Greenogue Business Park
Rathcoole Co. Dublin D24 FD63
Tel: 01 – 201 7675
Mob: 087 – 779 4905
Email: keith@loghouse.ie

Cork City Showroom

7 Days a week: 12 – 5pm



Hanley's of Cork, Frankfield
Co. Cork T12 C851
Tel: 021 – 243 9151
Email: steven@loghouse.ie
Mob: 085 – 861 3489
Email: denis@loghouse.ie
Mob: 087 – 139 0957

Athlone Showroom

7 Days a week: 10 – 5pm



Fernhill Garden Centre
Ballymahon Road, Cornanmagh
Athlone, Co. Westmeath
Tel: 090 – 661 6221
Mob: 087 – 394 8038
Email: dermot@loghouse.ie
Mob: 087 – 263 5941
Email: carlos@loghouse.ie

For full range of products please visit www.loghouse.ie